

DESCRIPTION

The CM7030 is a highly integrated single chip designed especially for Live Streaming Microphones, Headsets, Mixer Boxes, Speakers, or other peripherals. It features Cmedia's Xear™ SingFX vocal Echo/Reverb engine, Digital Parametric EQ, Smart Noise Suppression, AGC, Voice Prompts, and Vocal Fading circuits for general music. With SPDIF-Out, Analog I/O, digital/analog mixers, potentiometers, embedded MCU, flash memory, and oscillator inside the chip, the CM7030 is a cost-effective and ease-of-use single chip solution to fulfill Live Streaming applications, minimizing the total BOM cost and design complexity. It also supports cap-less/anti-pop headphone driver, jack-detection, tri-color LED PWM driver which could enhance the end product features and ease-of-use. High SNR/THD of Mic-In ADC (~85dB SNR at +20dB pre-amp gain) can achieve high recording/monitoring performance for microphone input.

FEATURES

- Xear™ SingFX sound processing including: Echo/Reverb, Record/Playback Parametric EQ, Smart Noise Suppression, AGC, and Vocal Fading, Voice prompts, Voice/Music mixing, etc.
- USB2.0 Full-Speed and UAC 1.0/2.0 compliant
- 2 channel microphone, 2 channel line in and 2 channel Music in
- 2 x stereo cap-less headphone out with 25mW@32Ω driving capability
- Embedded 8051 MCU/512KB flash with Firmware Protection
- Built-in 5-band parametric Equalizer for both playback and recording
- Integrated 4-channel SARADC with 7-bit resolution
- Integrated Tri-Color LED PWM driver
- Built-in S/PDIF output transmitter
- High SNR ADC for excellent microphone performance (~85dB@+20dB gain)
- Up to 96KHz/24bit Hi-Res playback or recording
- QFN-68 package (7 x 7 mm)

BLOCK DIAGRAM

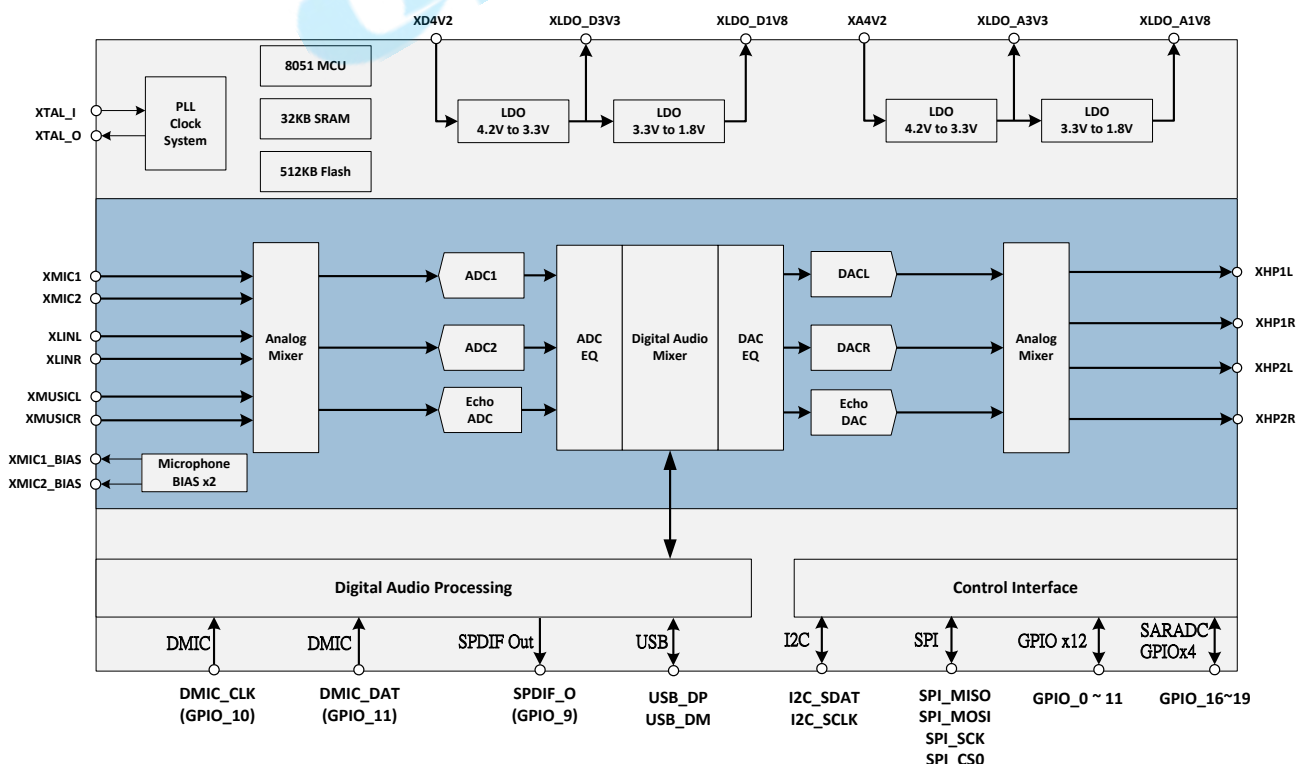

Release Notes

Revision	Date	Description
1.00	2021/05/11	Preliminary release
1.10	2022/08/15	Modify GPIO16~19 description of CH5.2 Modify smart receiver block of CH4.2/CH4.3 Update Power consumption of CH6.5
1.20	2025/07/01	Modify Electrical Characteristics

COPYRIGHT

©2020 C-Media Electronics Inc. All rights reserved. No part of this document may be reproduced, transmitted, transcribed, stored in a retrieval system, or translated into any language in any form or by any means without the written permission of C-Media Electronics Inc.

DISCLAIMER

Information furnished in this document by C-Media Electronics Inc. is for design and qualification reference. However, it may include some technical inaccuracies or typographical errors, and no warranty and responsibility is assumed by C-Media Electronics Inc. for its use, nor for any infringements of patents or other rights of third parties that may result from its use. No license is granted by implication or otherwise under any patent or patent rights of C-Media. More information update may be available afterwards and the contents may be subject to change, modification, or improvement without notice. Please contact C-Media representative for the latest or additional information that may be helpful to the development and ordering process. C-Media also assumes no liability for customers' final product design, application, verification, qualification, production, and distribution, storage, and usage problems. Customers should take good care and be responsible for their own final products and business using C-Media's ICs or solutions.

TRADEMARKS

C-Media/Cmedia logo/Xear are trademarks of C-Media Electronics Inc. Others mentioned in this document might be trademarks/registered trademarks of their respective owners.

TABLE OF CONTENTS

1	Release Notes	1
2	Description and overview	4
3	Features	4
3.1	Xear™ SingFX sound processing features for live Stream:	4
3.2	Smart receiver	4
3.3	AGC, Smart Noise Suppression(Noise Gate)	4
3.4	Audio I/O	4
3.5	Audio codec and mixer	5
3.6	USB compliance	6
3.7	Integrated 8051 micro-processor and flash	6
3.8	Digital control interface	6
3.9	Miscellaneous.....	7
3.10	Shutdown mode.....	7
3.11	Applications	7
4	Function block and mixer path	8
4.1	Analog mixer path.....	8
4.2	Playback audio signal processing	9
4.3	Recording audio signal processing	10
5	Pin assignment.....	11
5.1	Pin-out diagram.....	11
5.2	Pin description.....	12
6	Electrical characteristics.....	16
6.1	Absolute maximum ratings	16
6.2	Recommended operation conditions	16
6.3	DC Characteristics	16
6.4	Power consumption.....	16
6.5	Analog I/O characteristics.....	17
7	Audio performance.....	18
7.1	DAC audio quality	18
7.2	ADC audio quality	19
7.3	A-A path(sidetone) audio quality	20
8	Package dimensions.....	21

2 Description and overview

The CM7030 is a highly integrated single chip designed especially for Live Streaming Microphones, Headsets, Mixer Boxes, Speakers, or other peripherals. It features Cmedia's Xear™ SingFX vocal Echo/Reverb engine, Digital Parametric EQ, Smart Noise Suppression, AGC, Voice Prompts, and Vocal Fading circuits for general music. With SPDIF-Out, Analog I/O, digital/analog mixers, SARADC for potentiometers, embedded MCU, flash memory, and oscillator inside the chip, the CM7030 is a cost-effective and ease-of-use single chip solution to fulfill the Live Streaming applications, minimizing the total BOM cost and design complexity. It also supports 2 cap-less/anti-pop headphone drivers, jack-detection, tri-color LED PWM driver which could enhance the end product features and ease-of-use. High SNR/THD of Mic-In ADC (~85dB SNR at +20dB pre-amp gain) can achieve high recording/monitoring performance for microphone input.

3 Features

3.1 Xear™ SingFX sound processing features for live Stream:

- Digital Vocal Echo/Reverb engine
- Digital Parametric EQ for both recording/playback
- Digital/Analog sidetone monitoring
- Smart Noise Suppression/Smart Receiver (Noise Estimation)/AGC for Microphone recording (via FW processing & programming)
- Vocal Fading for transforming ordinary music into accompaniments
- Supports Voice or Sound Prompts playback (loaded from Flash)
- Stereo Mix path to record DAC output audio with inputs
- Complete Audio Mixer designed for Live Stream applications
- Mainly supports 48KHz/16bit processing(**Note 4)

3.2 Smart receiver

The smart receiver uses stereo microphones to sense environment noise and adjusts internal ADC gain automatically. It extracts envelope signal from microphone input and based on the results to increase (or decrease) gain dynamically.

The smart receiver function can also detect DAC and ADC signal to achieve AGC, Noise gate, compressor.

3.3 AGC, Smart Noise Suppression(Noise Gate)

CM7030 provide a flexible AGC function for ADC path. The smart receiver processes income audio signal samples. Then MCU monitors the output data to compute suitable analog gain to achieve target level and preventing clipping. The smart noise suppression function also could be implemented through adjusting digital volume.

3.4 Audio I/O

- Two true cap-less/zero-ground stereo headphone driver with anti-pop technology for power on/off

- Stereo microphone input with linear/low-noise preamp gain control (-15~+45dB) and microphone bias
- Supports Line-In and Aux-In (Music) ports for common music or accompaniments mixing
- Mono output pin for smart phone 3.5mm combo jack recording
- DMIC input interface
- Built-In S/PDIF output transmitter

3.5 Audio codec and mixer

- DACs:
 - Stereo DAC for playback
 - Sample Rates: 8K/11.025K/16K/22.05K/32K/44.1K/48K/88.2K/96KHz(**Note 3)
 - Supports Bit Length: 16/24bits
 - Speaker Gain Range (Analog) is -62 ~ 0dB, 1dB/step
 - DAC Gain Range (Digital) is -62 ~ 0dB, 1dB/step
 - Mono DAC for microphone effect
 - Sample Rates: 48K only
 - Supports Bit Length: 16 bits only
 - Speaker Gain Range (Analog) is -62 ~ 0dB, 1dB/step
 - DAC Gain Range (Digital) is -62 ~ 0dB, 1dB/step
- ADCs:
 - Stereo ADC for recording
 - Sample Rates: 8K/11.025K/16K/22.05K/32K/44.1K/48K/88.2k/96KHz(**Note 3)
 - Supports Bit Length: 16/24 bits
 - Microphone gain range (Analog) is -15 ~ 45dB, 1dB/step
 - ADC gain range (Digital) is -62 ~ 0dB, 1dB/step
 - Supports complete Analog/Digital mixer (for monitoring/side tone paths)
 - Mono ADC for microphone effect
 - Sample Rates: 48K only
 - Supports Bit Length: 16 bits only
 - Microphone gain range (Analog) is -15 ~ 45dB, 1dB/step
 - ADC gain range (Digital) is -62 ~ 0dB, 1dB/step
- A-A Side tone(**Note 2):
 - Analog input to analog output mixer path with independent volume control: -15 ~ +45dB, 1dB/step
- S/PDIF transmitter
 - Sample Rates: 44.1K/48K/88.2K/96KHz
 - Supports Bit Length: 16/24 bits

**Note 1: The settings/USB descriptors above are programmable by the embedded MCU firmware in the internal flash memory.

**Note 2: A-A means analog to analog mixer path

**Note 3: CM7030 is a USB 2.0 full speed audio device. Since bandwidth limitation, the supported combinations are shown below:

USB Descriptor	Playback	Capture
Playback with higher bandwidth	Stereo, 96KHz/24bits	Stereo, 48KHz/24bits or below
		Mono, 96KHz/24bits or below
Recording with higher bandwidth	Stereo, 48KHz/24bits or below	Stereo, 96KHz/24bits or below
	Mono, 96KHz/24bits or below	

**Note 4: Xear™ SingFX functions mainly support 48K/16bits sampling rate, such as voice prompt, echo/reverb, playback digital mixer and recording digital mixer, the supported combinations are shown below:

	Playback	Capture
Voice prompt	48KHz/16bits only	--
Echo/reverb	--	48KHz/16bit only
Playback digital mixer	48KHz/16bits only	--
Recording digital mixer	--	48KHz/16 bits only
Vocal Fading	96KHz/24bits or below	96KHz/24bits or below

3.6 USB compliance

- USB 2.0 full-speed compliant
- USB Audio Class 1.0/2.0 compliant
- USB Human Interface Device (HID) Class 1.1 compliant
- Supports USB suspend/resume/reset functions
- Supports control, interrupt, bulk, and isochronous data transfers

3.7 Integrated 8051 micro-processor and flash

- Embedded 8051 micro-processor with firmware protection
- Embedded 512KB Flash memory for FW program to save the external memory cost and PCB size
- HID interrupts can be implemented via firmware codes
- VID/PID/Product String/HW Configuration can be programmable via the MCU firmware
- Provides firmware upgrade capability through USB interface

3.8 Digital control interface

- Built-in Tri-color LED PWM Driver for fashionable shiny headset design
- Master/Slave I2C control interface (100/400Kbps)
- One high-speed 4-wire SPI master / slave interface (up to 12MHz)
- Max. 16 GPIO pins can be configured via firmware programming
- UART interface

3.9 Miscellaneous

- Up to 4-channel Successive-Approximation Register Analog-to-Digital Converter (SARADC) with 7-bit resolution for sound effect adjustment, battery, charger voltage detection, etc.

3.10 Shutdown mode

Shutdown mode is designed to turn CM7030 into ultra low-power state when it is not operated.

As shutdown mode enables, the internal regulator, crystal and PLL circuit will be powered off and the contents in SRAM and register will be cleared.

If you want to go back to normal operation status from Shutdown mode, you can change XDETSW or XDETCG signal level to wake up CM7030.

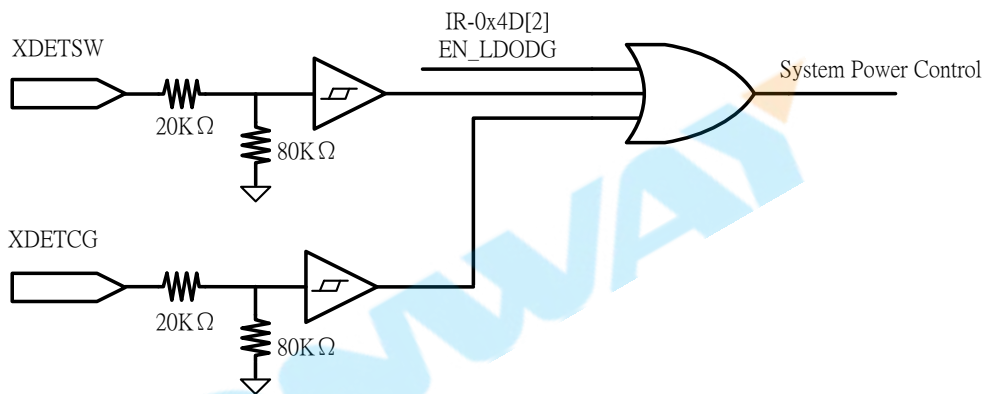

3.11 Applications

- USB Live Streaming Microphone
- USB Microphone
- USB Headset
- USB Live Streaming Mixer Box
- Other USB Audio Devices (Smart TV, OTT Box, Dock Stations... etc.)

4 Function block and mixer path

4.1 Analog mixer path

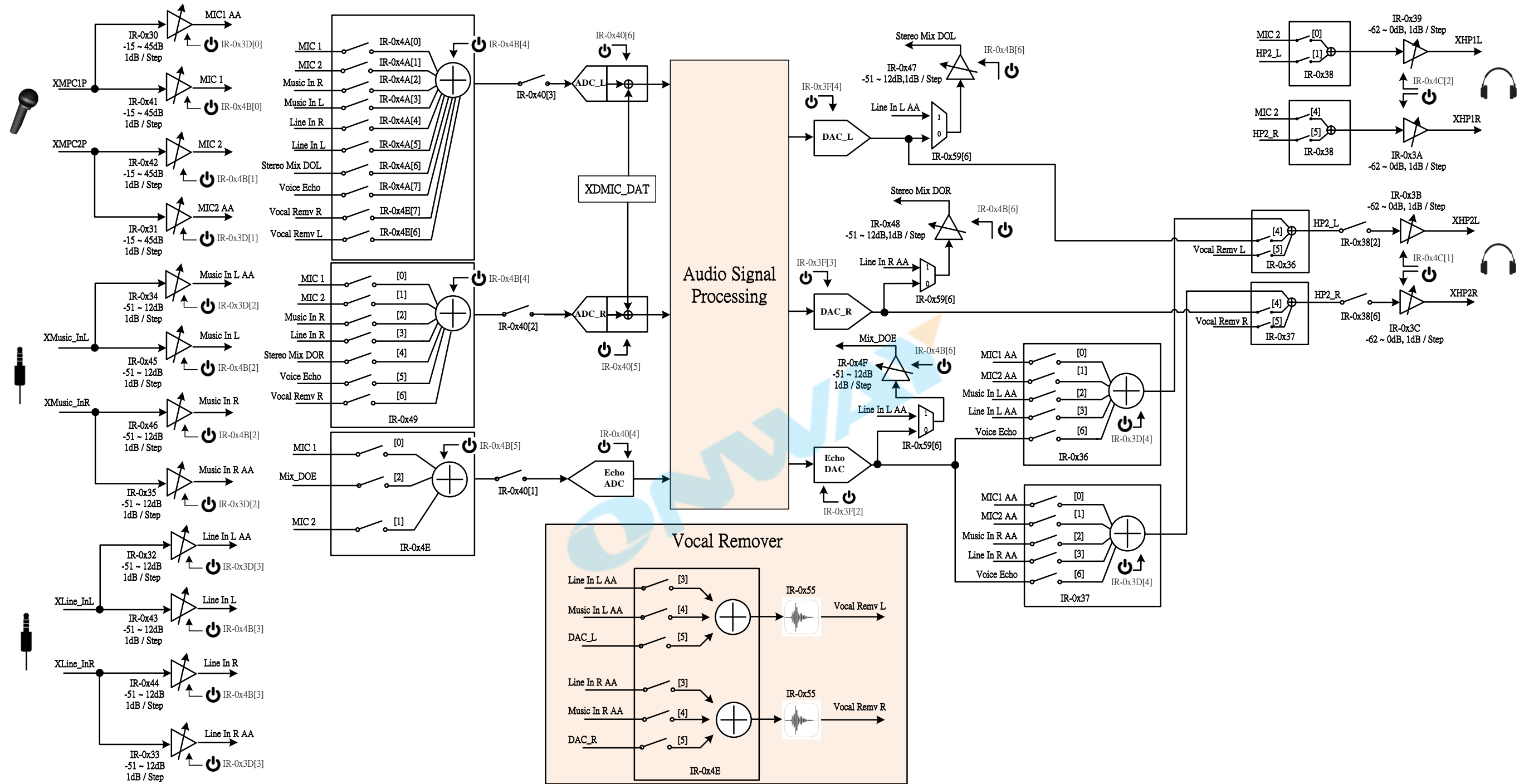

4.2 Playback audio signal processing

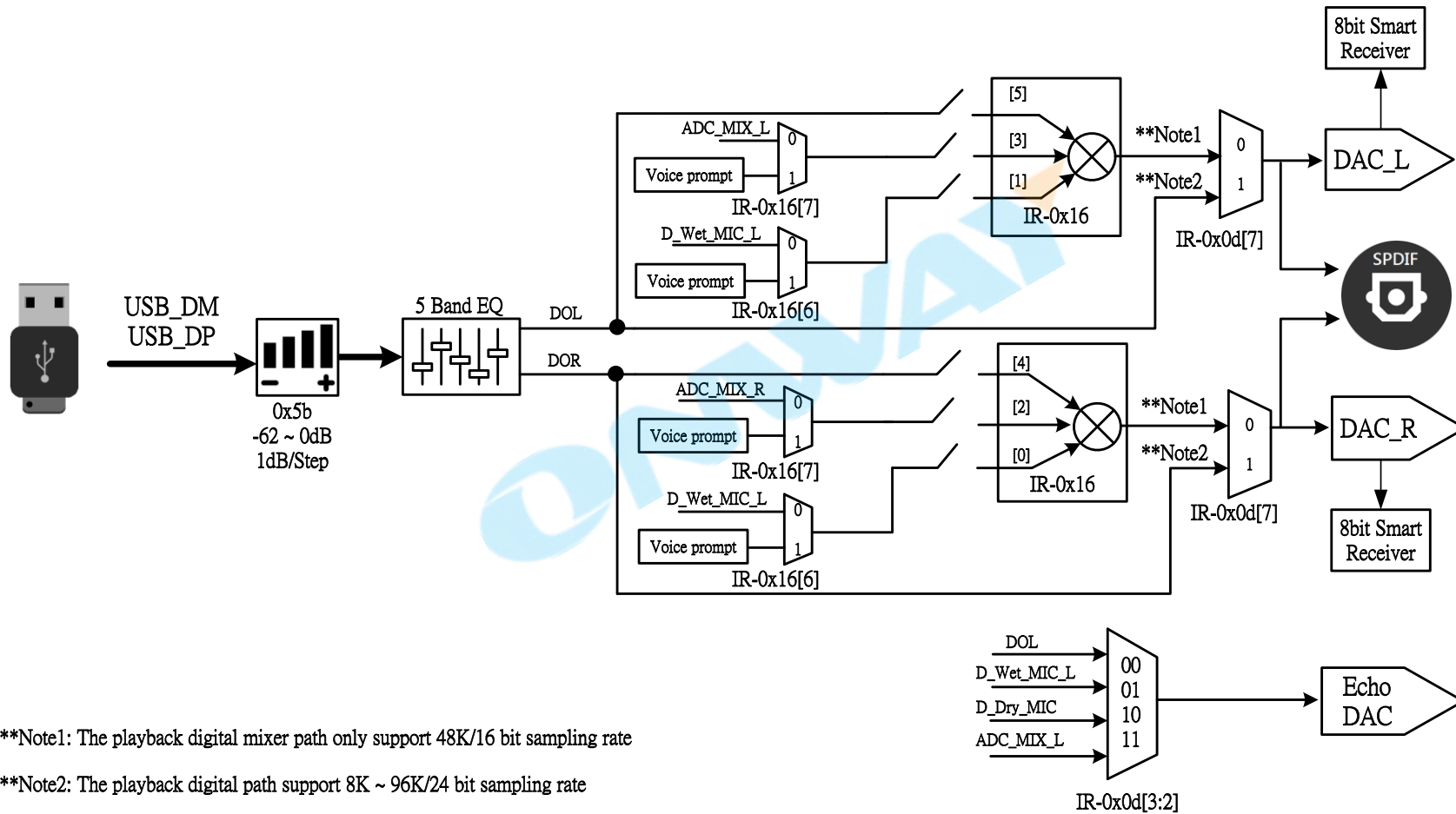

**Note1: The playback digital mixer path only support 48K/16 bit sampling rate

**Note2: The playback digital path support 8K ~ 96K/24 bit sampling rate

4.3 Recording audio signal processing

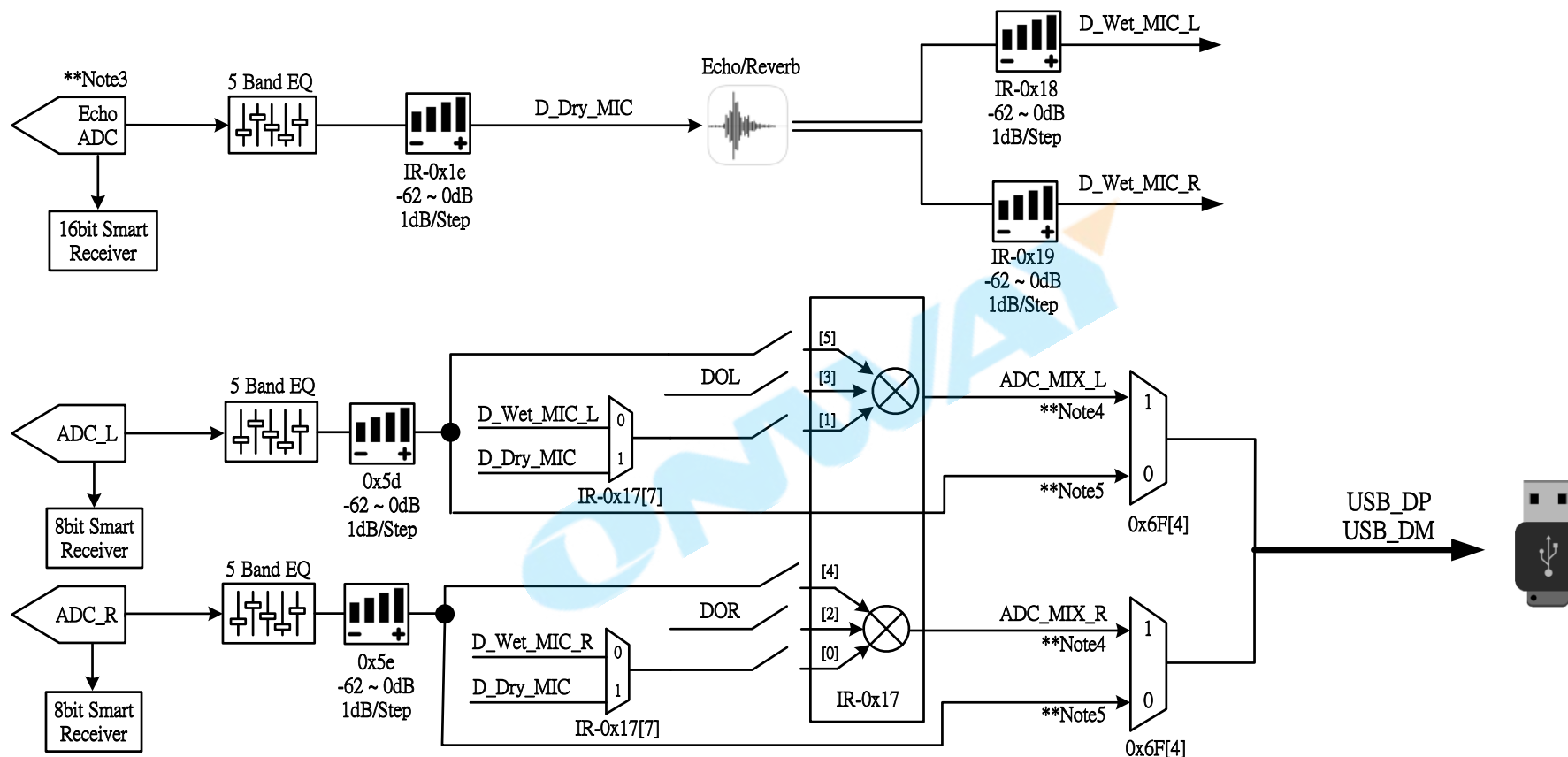

**Note3: The Echo ADC path only support 48K/16 bit sampling rate

**Note4: The recording digital mixer path only support 48K/16 bit sampling rate

**Note5: The recording digital path support 8K ~ 96K/24 bit sampling rate

5.2 Pin description

Pin #	Symbol	I/O	Description
USB2.0 FS BUS Interface			
11	USB_DP	AIO	USB data positive (USB D+ signal).
10	USB_DM	AIO	USB data negative (USB D- signal).
Clock			
67	XTAL_O	AO	12MHz crystal oscillator output
68	XTAL_I	AI	12MHz crystal oscillator input
Power/Ground			
14	XD4V2	PWR	Digital power for 4.2/1.8V regulator
31	XA4V2	PWR	Analog power for 4.2/1.8V regulator
13	XLDO_D3V3	AO	Digital regulator 3.3V output, drive capacity 10mA
30	XLDO_A3V3	AO	Analog regulator 3.3V output, no current drive capacity
12	XLDO_D1V8	AO	Digital regulator 1.8V output, no current drive capacity
32	XLDO_A1V8	AO	Analog regulator 1.8V output, no current drive capacity
28	XAGND	GND	Analog ground
69	DGND	GND	Digital ground (Exposed-Pad)
18	XVRH	AO	VR Bias H
17	XVRL	AO	VR Bias L
22	XMIC1_BIAS	AO	Microphone bias (2.75V) for XMIC1
24	XMIC2_BIAS	AO	Microphone bias (2.75V) for XMIC2
1	DV18_ESD	AO	Digital 1.8V output, no current drive capacity
9	DV33_ESD	AO	Digital 3.3V output, no current drive capacity
33	D1V8_NEG	AI	Charge pump 1.8V source input
50	XA1V8_HPL	AI	positive source for left channel headphone driver
46	XA1V8_HPR	AI	positive source for right channel headphone driver
Audio Interface			
49	XHP1L	AO	HP1 out left channel
44	XHP1R	AO	HP1 out right channel
48	XHP2L	AO	HP2 out left channel
45	XHP2R	AO	HP2 out right channel
25	XMUSICL	AI	Aux input left channel
26	XMUSICR	AI	Aux input right channel
21	XMIC1	AI	Microphone Input 1 (L channel)
23	XMIC2	AI	Microphone Input 2 (R channel)
19	XLINL	AI	Line input left channel
20	XLINR	AI	Line input right channel
GPIO			
66	GPIO_0	DIO	3.3V I/O, 5V tolerance, bidirectional buffer with 8mA driving current, Default weak pull-up for input.
65	GPIO_1	DIO	3.3V I/O, 5V tolerance, bidirectional buffer with 8mA driving current, Default weak pull-up for input.

64	GPIO_2	DIO	3.3V I/O, 5V tolerance, bidirectional buffer with 8mA driving current, Default weak pull-up for input.
63	GPIO_3	DIO	3.3V I/O, 5V tolerance, bidirectional buffer with 8mA driving current, Default weak pull-up for input.
62	GPIO_4	DIO	Programmable 2 in 1 I/O interface. GPIO/PWM select by firmware. General purpose input/output (default PWM LED Blue). 3.3V I/O, 5V tolerance, bidirectional buffer with 8mA driving current, Default weak pull-up for input.
61	GPIO_5	DIO	Programmable 2 in 1 I/O interface. GPIO/PWM select by firmware. General purpose input/output (default PWM LED Green). 3.3V I/O, 5V tolerance, bidirectional buffer with 8mA driving current, Default weak pull-up for input.
60	GPIO_6	DIO	Programmable 2 in 1 I/O interface. GPIO/PWM select by firmware. General purpose input/output (default PWM LED Red). 3.3V I/O, 5V tolerance, bidirectional buffer with 8mA driving current, Default weak pull-up for input.
59	GPIO_7	DIO	3.3V I/O, 5V tolerance, bidirectional buffer with 8mA driving current, Default weak pull-up for input.
58	GPIO_8	DIO	3.3V I/O, 5V tolerance, bidirectional buffer with 8mA driving current. Default Tri-state output.
57	GPIO_9	DIO	Programmable 2 in 1 I/O interface. GPIO/SPDIF Out select by firmware. 3.3V I/O, 5V tolerance, bidirectional buffer with 8mA driving current, Default weak pull-up for input.
56	GPIO_10	DIO	Programmable 3 in 1 I/O interface. GPIO/Digital MIC Clock (DMIC_CLK)/ UART_RX select by firmware. 3.3V I/O, 5V tolerance, bidirectional buffer with 8mA driving current, Default weak pull-up for input.
55	GPIO_11	DIO	Programmable 3 in 1 I/O interface. GPIO/Digital MIC Data (DMIC_DAT)/ UART_TX select by firmware. 3.3V I/O, 5V tolerance, bidirectional buffer with 8mA driving current, Default weak pull-up for input.
54	GPIO_16	DIO	Programmable 2 in 1 I/O interface. GPIO/SARADC0 (for voltage potentiometer) selected by firmware. 3.3V I/O, 5V tolerance, bidirectional buffer, Open Drain Output without current drive capacity, Default weak pull-up for input. SARADC<6:0> 0000000: Minium-----11.39mV 1111111: Maxium-----1.45V (11.39mV/Step)
53	GPIO_17	DIO	Programmable 2 in 1 I/O interface. GPIO/ SARADC1 (for voltage potentiometer) selected by firmware. 3.3V I/O, 5V tolerance, bidirectional buffer, Open Drain Output without current drive capacity, Default weak pull-up for input. SARADC<6:0> 0000000: Minium-----11.39mV 1111111: Maxium-----1.45V (11.39mV/Step)

52	GPIO_18	DIO	Programmable 2 in 1 I/O interface. GPIO/SARADC2 (for voltage potentiometer) selected by firmware. 3.3V I/O, 5V tolerance, bidirectional buffer, Open Drain Output without current drive capacity, Default weak pull-up for input. SARADC<6:0> 0000000: Minium-----11.39mV 1111111: Maxium-----1.45V (11.39mV/Step)
51	GPIO_19	DIO	Programmable 2 in 1 I/O interface. GPIO/SARADC3 (for voltage potentiometer) selected by firmware. 3.3V I/O, 5V tolerance, bidirectional buffer, Open Drain Output without current drive capacity, Default weak pull-up for input. SARADC<6:0> 0000000: Minium-----11.39mV 1111111: Maxium-----1.45V (11.39mV/Step)
4-Wire SPI Serial Bus			
5	SPI_MISO	DIO	SPI data master in/slave out, 3.3V I/O, 5V tolerance, bidirectional buffer with 8mA driving current, Default weak pull-down for input.
6	SPI_MOSI	DIO	SPI data master out/slave in, 3.3V I/O, 5V tolerance, bidirectional buffer with 8mA driving current, Default weak pull-down for input.
7	SPI_CS0	DIO	SPI chip select, 3.3V I/O, 5V tolerance, bidirectional buffer with 8mA driving current, Default weak pull-up for input.
8	SPI_SCK	DIO	SPI clock, 3.3V I/O, 5V tolerance, bidirectional buffer with 8mA driving current, Default weak pull-down for input.
2-Wire Serial Bus (I2C)			
2	I2C_SDAT	DIO	2-wire serial data, 3.3V I/O, 5V tolerant, bidirectional buffer with 8mA driving current, Default weak pull-up for input.
3	I2C_SCLK	DIO	2-wire serial clock, 3.3V I/O, 5V tolerant, bidirectional buffer with 8mA driving current, Default weak pull-up for input.
Miscellaneous			
4	TEST	DI	The TEST pin is used IC test, another one is in the situation when F/W was crash or USB was not recognized, Set TEST pin to 3.3V before USB connect can force MCU into boot loader mode and able to update F/W via configuration tool, Default weak pull-down for input. 1: Boot loader mode 0 or floating: Normal operation ** Connect to GND by default.
15	XDETSW	AI	Wakeup pin for Shutdown mode, level trigger input. Keep VIH >100m Sec can wake up from Shutdown mode VIH:1.5V, VIL:0.8V **Pull up to 4.2V if not used
16	XDETCG	AI	Wakeup pin for Shutdown mode, level trigger input. Keep VIH >100m Sec can wake up from Shutdown mode VIH:1.5V, VIL:0.8V **Pull up to 4.2V if not used

42	CHP_N_NEG	AI	Charge pump cap
34	CHP_P_NEG	AI	Charge pump cap
29	XVRP_PAD	AI	DAC High Level reference
27	XVREF	AI	analog common reference
47	XVNEG_HPL	AI	Negative source for left channel headphone driver
43	XVNEG_HPR	AI	Negative source for right channel headphone driver
35	VNEG_NEG	AO	Charge pump negative voltage output
38	XLPFOL	AO	Vocal Fading, left channel filter op output
37	XLPFIL	AI	Vocal Fading, left channel filter op input
41	XLPFOR	AO	Vocal Fading, right channel filter op output
40	XLPFIR	AI	Vocal Fading, right channel filter op input
36	XMUXL	AO	Vocal Fading, left channel signal to filter
39	XMUXR	AO	Vocal Fading, right channel signal to filter

**Note: GPIOs, I2C, SPI, SPDIF and all audio Interface pins can be left floating if not used.

ONWAVE

6 Electrical characteristics

6.1 Absolute maximum ratings

Parameter	Symbol	Min.	Typ	Max.	Unit
Storage temperature	T_s	-40	-	125	°C
supply voltage	XD4V2 XA4V2	-	-	5.5	V
ESD (Body mode)	HBM	-	±3500	-	V
ESD (Machine mode)	MM	-	±200	-	V

6.2 Recommended operation conditions

Parameter	Symbol	Min.	Typ	Max.	Unit
Operating ambient temperature	T_A	0	25	70	°C
supply voltage	XD4V2 XA4V2	3.3	4.2	5.2	V
MCU Clock	-		12.000		MHz

6.3 DC Characteristics

Test Conditions: XD4V2=4.2V,XA4V2=4.2V, DVDD33=3.3V, DGND =0V, TA=+25 °C

Parameter	Symbol	Min.	Typ	Max.	Units
Input voltage range	DI	0		5.5	V
Output voltage range	DO	0		3.3	V
Input Voltage High	VIH	2.3	3.3	5.5	V
Input Voltage Low	VIL	-	-	1	V
Output Voltage High	VOH	2.97	-	-	V
Output Voltage Low	VOL	-	-	0.33	V
Output source current	IOH		8		mA
Output sink current	IOL		8		mA
VREG driver current	IVREG			10	mA

6.4 Power consumption

Test Conditions: DGND =0V, TA=+25 °C, MCU Clock = 48MHz @USB Active, Sample Rate=48KHz, 16Bits, EQ/SPDIF-Out/A-A disable, No loading

Items	Test Conditions	Test Values			Unit
		Min.	Typ.	Max.	
Current consumption @ USB Active (48MHz Clock)	USB Play + Record (XD4V2 = XA4V2 = 4.2V)		93		mA
Current consumption @ Suspend	USB Suspend		500		uA
Current consumption @ Shutdown	Shutdown mode		28		uA

6.5 Analog I/O characteristics

Parameter	Symbol	Pin Name	Limit Values			Unit	Test Conditions
			Min.	Typ.	Max		
Microphone Input Impedance	MII	MIC IN		20		k Ω	
Microphone A-A Input Impedance	MAII	MIC IN		10		k Ω	
Microphone Bias Open Circuit Voltage	VMICBIAS	MICBIAS	2.55	2.75	2.95	V	
Microphone Bias Output Current	IMICBIAS	MICBIAS			1.25	mA	RMIN=2.2k Ω

ONWAVE

7 Audio performance

7.1 DAC audio quality

TA=25°C, XD4V2=4.2V, XA4V2=4.2V, 1KHz Sine wave, 48KHz/16bit, 33ohms cascading resistor ([Note](#)), Equalizer disable

Test Platform: DELL Desktop 32BWS02, 4G RAM, Windows 10

Items	Test Conditions	Test Values			Unit
		Min.	Typ.	Max.	
Full Scale Output Voltage	10KΩ loading		980		mVrms
	32Ω loading		480		mVrms
THD+N	10KΩ loading -3dBFS		-85dB (@1KHz)		dB
	32Ω loading -3dBFS		-68dB (@1KHz)		dB
Dynamic Range	32Ω loading -60dBFS, A-Weighted		89		dB
SNR (Noise level during playback)	10KΩ loading -96dBFS, A-Weighted		90		dB
	32Ω loading -96dBFS, A-Weighted		90		dB
Inter-Channel Phase Delay	100Hz ~ 20kHz	+0.09		+0.77	Deg
Sampling Frequency Accuracy	10KΩ loading	-0.0031		+0.0052	%
Channel Separation(Crosstalk)	10KΩ loading		-86		dB
	32Ω loading		-67		dB
Frequency Response	10KΩ loading	+0.091 (20Hz)		-0.968 (20KHz)	dB
	32Ω loading	+0.151 (20Hz)		-0.948 (20KHz)	dB
Passband Ripple	10KΩ loading			0.275	dB
	32Ω loading			0.281	dB

Note: Headphone 32 ohm loading audio quality measure by cascading 33 ohm resistors, the schematic diagram as below.

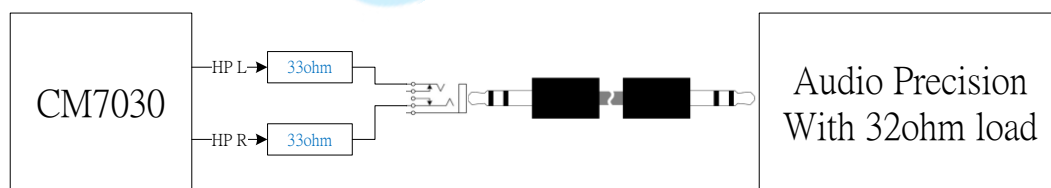

7.2 ADC audio quality

TA=25°C, XD4V2=4.2V, XA4V2=4.2V, Mic input 1KHz sine wave, 48kHz/16bit, Equalizer disable, AGC off
 ADC Gain=0dB, Test Platform DELL Desktop 32BWS02, 4G RAM, Windows 10

Items	Test Conditions	Test Values			Unit
		Min.	Typ.	Max.	
Full Scale Input Voltage	Microphone fs=48kHz		710		mVrms
THD+N	Microphone fs=48kHz/16bit, -3dBFS		-80		dB
Dynamic Range	Microphone fs=48kHz/16bit, -60dBFS, A-Weighted		88		dB
SNR (Noise level during record)	Microphone Gain =0dB fs=48kHz/16bit, -96dBFS, A-Weighted		89		dB
	Microphone Gain =20dB fs=48kHz/16bit, -96dBFS, A-Weighted		85		dB
Sampling Frequency Accuracy	Microphone fs=48kHz/16bit	-0.0061		+0.0053	%
Channel Separation (L/R Crosstalk)	Microphone fs=48kHz/16bit		-96		dB
Frequency Response	Microphone fs=48kHz/16bit	-0.086 (20Hz)		-0.96 (20KHz)	dB
Passband Ripple	Microphone fs=48kHz/16bit		0.239		dB

7.3 A-A path(sidetone) audio quality

TA=25 °C, XD4V2=5V, A-A Volume=0dB, 1KHz Sine wave, Mic-In to HP-Out, 33ohms cascading resistor

Test Platform: DELL Desktop 32BWS02, 4G RAM, Windows 10

Items	Test Conditions	Test Values			Unit
		Min.	Typ.	Max.	
Full Scale Output Voltage	10KΩ loading		970		mVrms
	32Ω loading		470		mVrms
THD+N	10KΩ loading, -3dBFS		-86		dB
	32 Ω loading, -3dBFS		-66		dB
Dynamic Range	32 Ω loading, -60dBFS, A-Weighted		93		dB
SNR (Noise level during active)	32Ω loading, -96dBFS, A-Weighted		93		dB
Channel Separation (Cross-talk)	10KΩ loading,		-87		dB
	32Ω loading		-71		dB
Frequency Response	10KΩ loading	-0.20 (100Hz)		0.998 (20KHz)	dB
Passband Ripple	10KΩ loading		0.07		dB

8 Package dimensions

QFN-68 pin (7x7 mm)

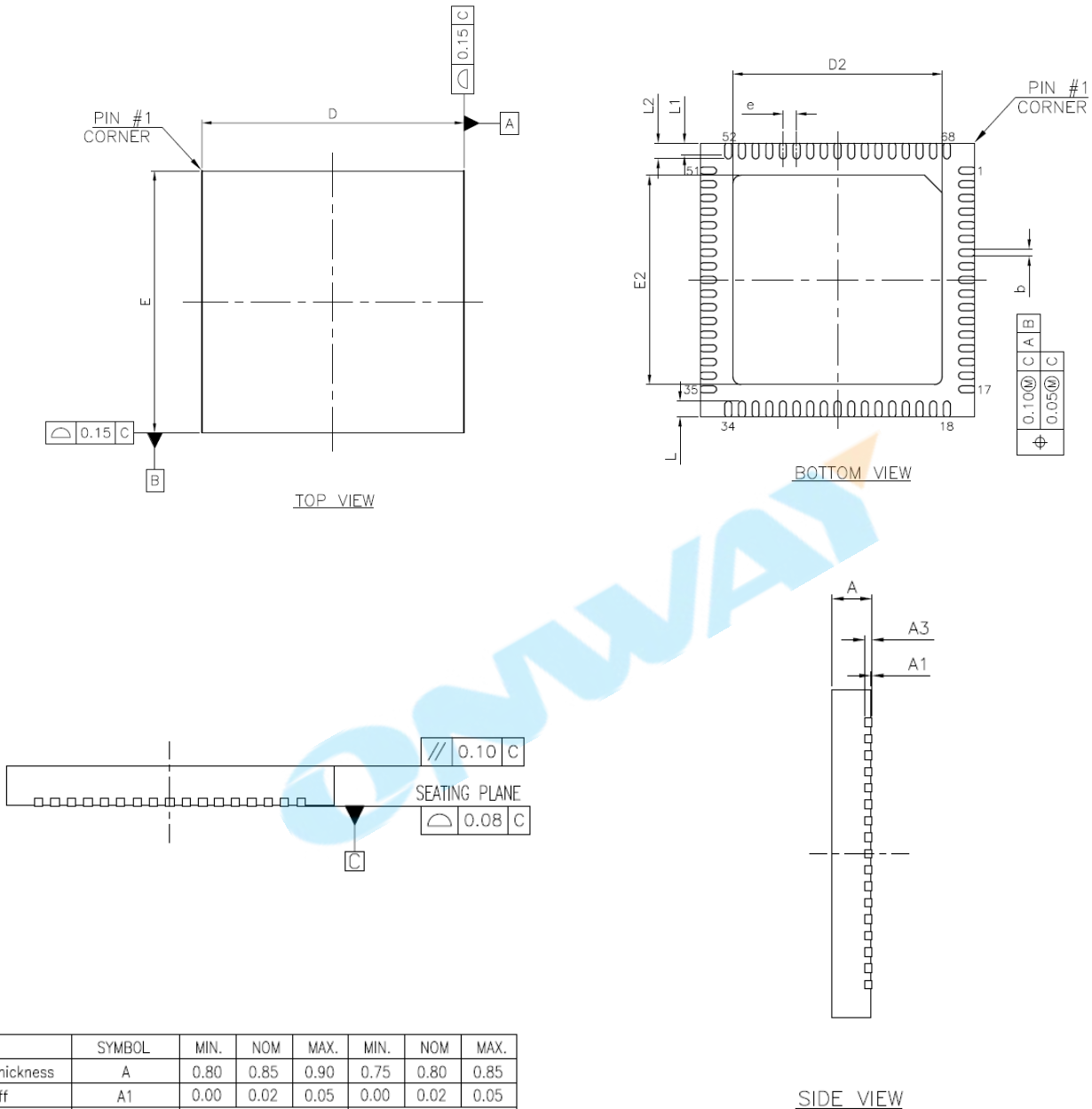

	SYMBOL	MIN.	NOM	MAX.	MIN.	NOM	MAX.
Total thickness	A	0.80	0.85	0.90	0.75	0.80	0.85
Standoff	A1	0.00	0.02	0.05	0.00	0.02	0.05
Lead thickness	A3	0.15 REF.			0.15 REF.		
Body size	D	6.90	7.00	7.10	6.90	7.00	7.10
	E	6.90	7.00	7.10	6.90	7.00	7.10

BBD no	Pad size	Lead width			Exposed pad width			Exposed pad length			Lead pitch			Lead length						LEAD FINISH				
		b			D2			E2			e			L		L1		L2		Pure Tin	PPF			
		MIN.	NOM	MAX.	MIN.	NOM	MAX.	MIN.	NOM	MAX.	MIN.	NOM	MAX.	MIN.	NOM	MAX.	MIN.	NOM	MAX.					
	231x231 MIL	0.13	0.18	0.23	5.26	5.36	5.46	5.26	5.36	5.46	0.35 BSC			0.35	0.40	0.45	--	0.31	--	--	0.39	--	V	X

— End of Datasheet —

ONWAY

C-MEDIA ELECTRONICS INC.
6F., 100, Sec. 4, Civil Boulevard, Taipei, Taiwan 106 R.O.C.
TEL : +886-2-8773-1100
FAX : +886-2-8773-2211
E-MAIL : sales@cmedia.com.tw