



DESCRIPTION

The CM6542 is the new generation ultra-low-power USB audio single chip designed especially for mobile USB-C headset, audio adapter or dock applications. It features cap-less/anti-pop headphone driver, combo-jack swap & jack-detection, Google buttons detection, embedded oscillator, flash, tri-color LED PWM driver, Digital EQ, DC-DC converter, etc., which can fulfill cost-effective, low-power, and versatile USB Type-C Audio accessories in a concise design for Android smartphones, tablets, New iPad Pro(2018), and PC. It also supports automatic power-down and active modes switch when the 3.5mm headset is unplugged or plugged-in to save the power consumption in USB-C audio adapter/dongle applications. Besides, it has Google headset 4-button in-line control detection and CTIA/OMTP typed headset/headphone auto switch. The integrated digital EQ and tri-color LED driver can bring more differentiation to the USB-C audio accessories. Up-to -96KHz/24bit codec support can facilitate Hi-Res Audio products.

FEATURES

- Supports complete power management with auto power-down mode (no 3.5mm headset plug-in)
- Ultra-low-power consumption design with internal DC-DC converter (@USB5V) : 0A @ power-down; 12.7mA @standby; 19.1mA @active playback
- Accepts USB 5V or 3.3V power supply
- Embedded 8051 MCU with internal 512KB flash
- Embedded oscillator for Crystal-less design
- True Cap-less/zero-ground headphone driver with patent applied anti-pop technology
- Supports OMTP and CTIA 4-ring combo jack auto switch and jack detection
- Supports 4 in-line Google buttons headset detection
- Built-in 5-band parametric Equalizer for both playback and recording
- Integrated Tri-Color LED PWM driver
- 2-ch DACs w/ 96dB SNR; 1-ch ADC 90dB SNR
- Up to 96KHz/24bit Hi-Res playback or recording
- Built-in S/PDIF transmitter
- USB2.0 Full-Speed and USB Audio Device Class 1.0
- CM6542 Small QFN-48 package (5x5 mm)

BLOCK DIAGRAM

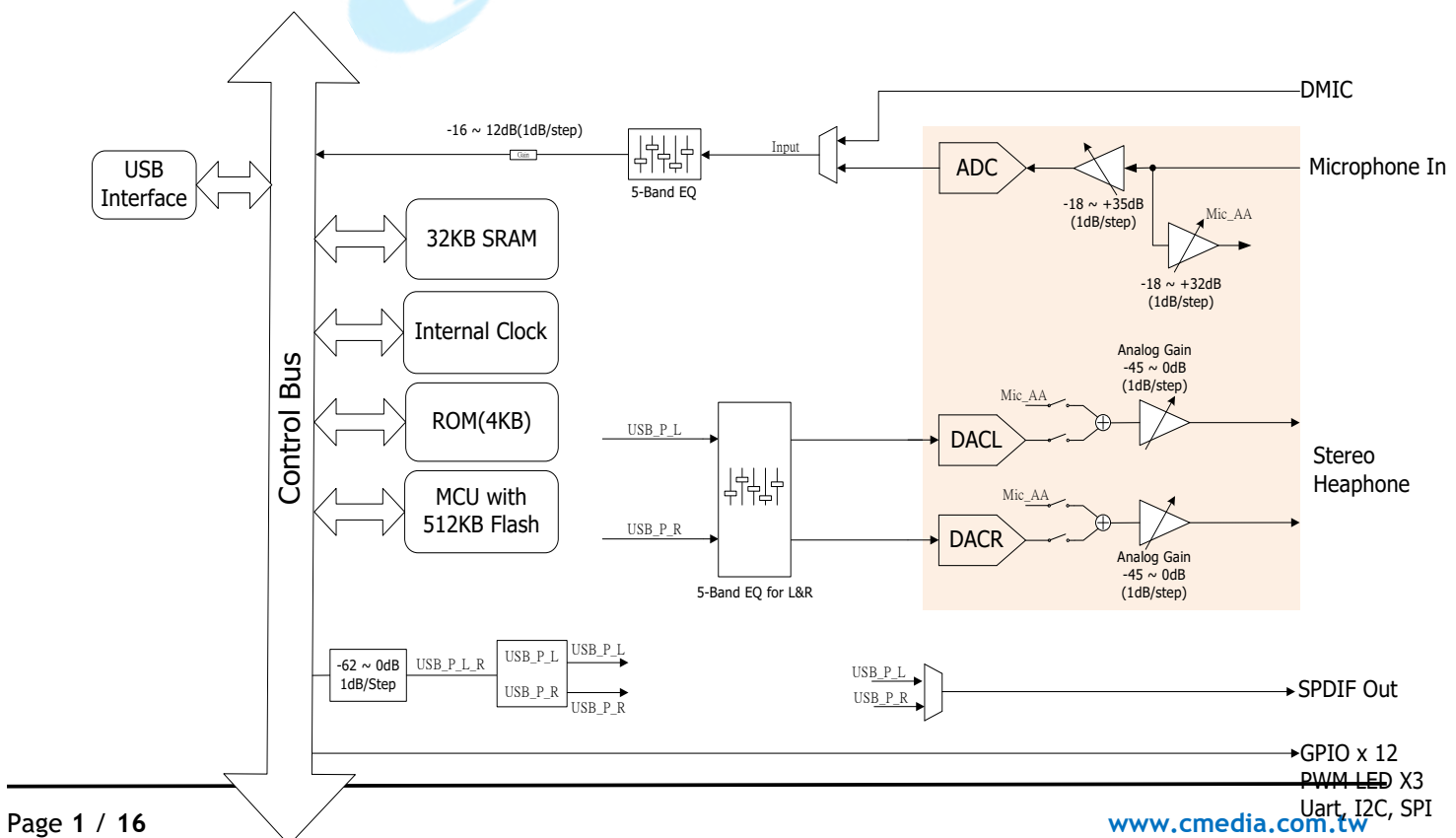

Release Notes

Revision	Date	Description
0.91	2019/08/05	Preliminary version
0.92	2019/08/28	Add DMIC function
0.93	2019/09/03	Modify voltage rage
0.94	2019/10/04	Modify gain rage
1.00	2019/12/08	Formal release
1.10	2020/01/02	Marking Information
1.20	2020/01/31	Modify Power Consumption
1.30	2020/02/11	Modify Operation Voltage range
1.31	2020/04/09	Modify Pin40 Description
1.32	2020/04/13	Modify ADC Full Scale Output Voltage
1.40	2020/04/16	Modify Package Dimensions
1.41	2020/04/16	Modify DAC Audio Quality
1.50	2020/07/21	Modify Package Dimensions
1.60	2020/09/10	Modify Description
1.70	2021/03/25	Modify Marking Information
1.80	2021/06/16	Modify Description
1.90	2021/08/17	Modify Description
1.91	2024/07/26	Modify Microphone Bias voltage
1.92	2024/04/09	Modify Electrical Characteristics
1.93	2025/07/07	Remove AGC Function

TABLE OF CONTENTS

1	Description and Overview	4
2	Ordering Information	4
3	Features	4
3.1	Ultra-Low-Power Design	4
3.2	Audio I/O.....	4
3.3	Audio Engine and Codec	4
3.4	USB Compliance.....	5
3.5	Integrated 8051 Micro-processor	5
3.6	Digital/Control Interface	5
3.7	Miscellaneous.....	6
4	Applications	6
5	Pin Assignment	7
5.1	Pin-out Diagram	7
5.2	Pin Description	8
6	Electrical Characteristics	11
6.1	Absolute Maximum Ratings	11
6.2	Recommended Operation Conditions	11
6.3	Power Consumption	11
6.4	DC Characteristics	11
6.5	Analog I/O Characteristics	11
6.6	Audio Performance	12
7	Package Dimensions (QFN-48 pin) (5x5 mm)	13
8	Top Marking	14

1 Description and Overview

The CM6542 is the new generation ultra-low-power USB audio single chip designed especially for mobile USB-C headset, audio adapter or dock applications. It features cap-less/anti-pop headphone driver, combo-jack swap & jack-detection, Google buttons detection, embedded oscillator, flash, tri-color LED PWM driver, Digital EQ, DC-DC converter, etc., which can fulfill cost-effective, low-power, and versatile USB Type-C Audio accessories in a concise design for Android smartphones, tablets, New iPad Pro(2018), and PC. It also supports power-down and active modes auto switch when the 3.5mm headset is unplugged or plugged-in. While no playback or recording activities, it will enter Standby mode to save the codec power consumption in USB-C audio adapter/dongle applications. Besides, it has Google headset 4-button in-line control detection and 4-ring CTIA/OMTP typed headset/3-ring headphone auto identification and switch. The integrated digital parametric 5-band Equalizers for both playback & recording streams and tri-color LED driver can bring more differentiation to the USB-C audio accessories. Up-to 96KHz/24bit codec support can facilitate Hi-Res Audio products.

2 Ordering Information

Product Name	Package Marking	Package Type	Transport Media
CM6542	CM6542	QFN-48 (5 x 5 mm)	Tray

3 Features

3.1 Ultra-Low-Power Design

- Supports complete power management including power-down, standby (idle), active modes
- Supports auto power-down mode while 3.5mm headset is unplugged
- Built-in high efficiency DC-DC converter to avoid power consumption of analog regulators
- Low-power true Cap-less/zero-ground headphone driver with “Dynamic Power Saving” feature to adjust the power voltage according to the playback audio content dynamically
- Current consumption (@USB5V) : 0A @ power-down; 12.7mA @standby; 19.1mA @active playback
- Accepts single USB 5V or 3.3V power supply (3.3V can even lower the total power consumption)

3.2 Audio I/O

- True cap-less/zero-ground stereo headphone driver with patent applied anti-pop technology for power on/off
- Built-in charge pump for internal +/- power rails
- Mono microphone input with linear/low-noise preamp gain control and mic bias
- Supports different 4-pole headsets: CTIA/OMTP mic/ground auto switch
- 4-ring headset combo jack detection (plugging & unplugging)
- Supports 4 in-line Google Android headset buttons detection (Play_Pause/Vol+/Vol-/VoiceCommand)
- S/PDIF Out transmitter

3.3 Audio Engine and Codec

- Playback Stream:
 - Stereo DAC:
 - Sample Rates: 8K/11.025K/16K/22.05K/32K/44.1K/48K/88.2K/96K Hz
 - Bit Depth: 16/24 bit

- Analog Gain Range: -45 ~ 0dB, 1dB/step
- Digital Gain Range: -62 ~ 0dB, 1dB/step
- SNR: ~96dB
- S/PDIF Transmitter:
 - Sample Rates: 44.1K/48K/88.2K/96K
 - Bit Depth: 16/24 bits
- 5-band Digital Parametric Equalizer
- Recording Stream:
 - Mono ADC
 - Sample Rates: 8K/11.025K/16K/22.05K/32K/44.1K/48K/88.2K/96K
 - Bit Depth: 16/24 bits
 - Microphone gain range is -18 ~ +35dB, 1dB/step
 - Digital Gain Range: -16 ~ +12dB, 1dB/step
 - SNR: ~90dB (86dB @+20dB Mic gain)
 - 5-band Digital Parametric Equalizer
- A-A Mixer (Sidetone):
 - Analog input to analog output mixer path with independent volume control: -18 ~ +32dB, 1dB/step

Note: The settings/USB descriptors above are programmable by the embedded MCU firmware in the internal flash memory.

3.4 USB Compliance

- USB 2.0 full-speed compliant
- USB Audio Class 1.0 compliant
- USB Human Interface Device (HID) Class 1.1 compliant
- Supports USB suspend/resume/reset functions
- Supports control, interrupt, bulk, and isochronous data transfers

3.5 Integrated 8051 Micro-processor

- Embedded 8051 micro-processor to handle the command/protocol transactions
- Embedded 512KB Flash memory for FW to save the external memory cost and size
- HID interrupts can be implemented via firmware codes
- VID/PID/Product String/USB Audio Descriptors/HW Configuration can be programmable via the MCU firmware
- Provides firmware upgrade capability through USB interface

3.6 Digital/Control Interface

- Built-in Tri-color LED PWM Driver for fashionable shiny headset design
- Master/Slave I2C control interface (100/400Kbps)

- One high-speed 4-wire SPI master / slave interface (150K to 12M bps)
- Max. 12 GPIO pins can be configured via firmware programming (3.3V digital I/O pads with 5V tolerance)
- USB HID button controls such as Vol+/Vol-/Play_Pause/Next/Previous/Playback Mute/etc. could be done via GPIO pins and FW programming

3.7 Miscellaneous

- Integrated oscillator/PLL circuit for crystal-less design (saving the external crystal)
- Industrial standard QFN-48 small package (5x5 mm)

4 Applications

- Low-power USB-C Audio Adaptors (USB to 3.5mm headset jack, with or w/o USB PD charging feature) for Android Smartphones/Apple New iPad Pro/PC
- Low-power USB-C Headsets for Android Smartphones/Apple New iPad Pro/PC
- USB-C Audio Dock Stations for Android Smartphones/Apple New iPad Pro/PC
- Low-power/High-quality USB Microphone

ONWAVE

5 Pin Assignment

5.1 Pin-out Diagram

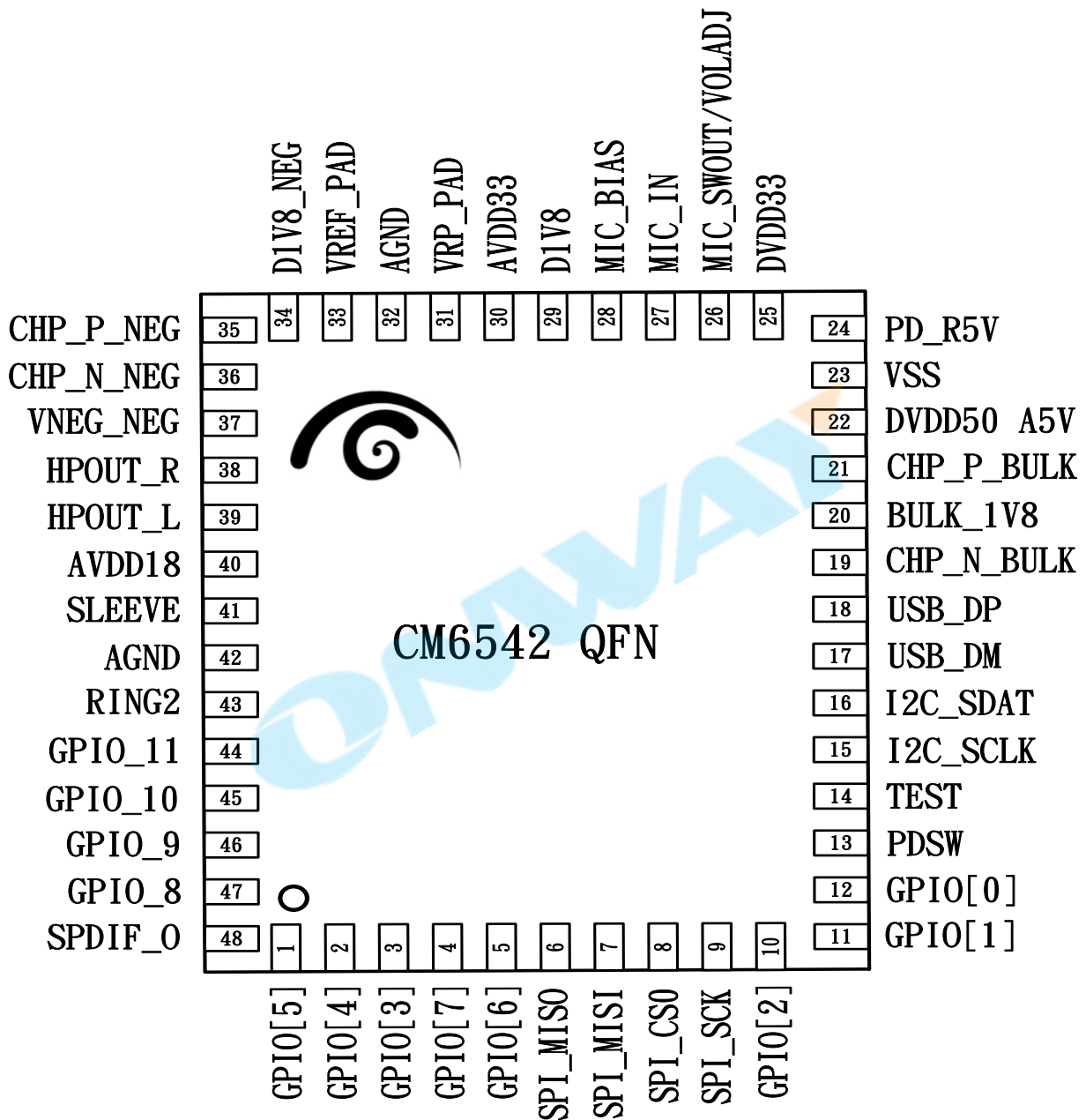

5.2 Pin Description

Pin #	Symbol	I/O	Description
USB2.0 FS BUS Interface			
18	USB_DP	AIO	USB data positive (USB D+ signal).
17	USB_DM	AIO	USB data negative (USB D- signal).
Power/Ground			
25	DVDD33	AO	Digital 3.3V regulator output, drive capacity
29	D1V8	AO	Digital 1.8V output, no current drive capacity
22	DVDD50 A5V	PWR	USB5V digital/analog single power
30	AVDD33	PWR	Analog 3.3V regulator output, no current drive capacity
34	D1V8_NEG	PWR	Power of negative charge pump
40	AVDD18	PWR	Analog 1.8V input to Digital power
19	CHP_N_BULK	PWR	Charge pump negative output of DC to DC
20	BULK_1V8	PWR	DC to DC step down regulator output
21	CHP_P_BULK	PWR	Charge pump positive output of DC to DC
23	VSS	GND	Digital Ground
42	AGND	GND	Analog Ground
32	AGND	GND	Analog Ground
37	VNEG_NEG	PWR	Negative charge pump output
36	CHP_N_NEG	PWR	Charge pump negative output of DC to DC
35	CHP_P_NEG	PWR	Charge pump positive output of DC to DC
49	VSS	GND	Digital Ground.
Audio Interface			
43	RING2	AI	Combo jack connector: Ring2
41	SLEEVE	AI	Combo jack connector: Sleeve
27	MIC_IN	AI	Microphone Input
28	MIC_BIAS	AO	Microphone Bias for ECM microphone
26	MIC_SWOUT/ VOLADJ	AIO	Combo jack switch output to microphone input pin; or potentiometer input (SAR ADC) when combo jack switch is not used
33	VREF_PAD	AO	Voltage reference for common mode voltage
31	VRP_PAD	AO	Voltage reference for DAC
39	HPOUT_L	AO	Line/HP out left channel
38	HPOUT_R	AO	Line/HP out right channel
S/PDIF I/O			
48	SPDIF_O	DO	S/PDIF transmitter SPDIF_O is an output buffer with 8mA Tri-state.
GPIO			
12	GPIO_0	DIO	3.3V I/O, 5V tolerance, bidirectional buffer with 8mA driving current, Default weak pull-up for input
11	GPIO_1	DIO	3.3V I/O, 5V tolerance, bidirectional buffer with 8mA driving current, Default weak pull-up for input
10	GPIO_2	DIO	3.3V I/O, 5V tolerance, bidirectional buffer with 8mA driving current, Default weak pull-up for input
3	GPIO_3	DIO	3.3V I/O, 5V tolerance, bidirectional buffer with 8mA driving current, Default weak pull-up for input
2	GPIO_4	DIO	3.3V I/O, 5V tolerance, bidirectional buffer with 8mA driving current, Default weak pull-up for input
1	GPIO_5	DIO	3.3V I/O, 5V tolerance, bidirectional buffer with 8mA driving current, Default weak pull-up for input

5	GPIO_6	DIO	3.3V I/O, 5V tolerance, bidirectional buffer with 8mA driving current, Default weak pull-up for input
4	GPIO_7	DIO	3.3V I/O, 5V tolerance, bidirectional buffer with 8mA driving current, Default weak pull-up for input
47	GPIO_8	DIO	3.3V I/O, 5V tolerance, bidirectional buffer with 8mA driving current, Default weak pull-up for input
46	GPIO_9	DIO	3.3V I/O, 5V tolerance, bidirectional buffer with 8mA driving current, Default weak pull-up for input
45	GPIO_10	DIO	(DMIC_CLK) 3.3V I/O, 5V tolerance, bidirectional buffer with 8mA driving current, Default weak pull-up for input
44	GPIO_11	DIO	(DMIC_DAT) 3.3V I/O, 5V tolerance, bidirectional buffer with 8mA driving current, Default weak pull-up for input
4-Wire SPI Serial Bus			
6	SPI_MISO	DIO	SPI data master in/slave out, 3.3V I/O, 5V tolerance, bidirectional buffer with 8mA driving current, Default weak pull-down for input
7	SPI_MOSI	DIO	SPI data master out/slave in, 3.3V I/O, 5V tolerance, bidirectional buffer with 8mA driving current, Default weak pull-down for input
8	SPI_CS0	DIO	SPI chip select, 3.3V I/O, 5V tolerance, bidirectional buffer with 8mA driving current, Default weak pull-up for input
9	SPI_SCK	DIO	SPI clock, 3.3V I/O, 5V tolerance, bidirectional buffer with 8mA driving current, Default weak pull-down for input
2-Wire Serial Bus (I2C)			
16	I2C_SDAT	DIO	2-wire serial data, 3.3V I/O, 5V tolerant, bidirectional buffer with 8mA driving current, Default weak pull-up for input
15	I2C_SCLK	DIO	2-wire serial clock, 3.3V I/O, 5V tolerant, bidirectional buffer with 8mA driving current, Default weak pull-up for input
Miscellaneous			
13	PDSW	DO	Power Down Switch is an output buffer with 8mA Tri-state output Active mode: 0 Suspend mode: 1
14	TEST	DI	The TEST pin is used IC test, another one is in the situation when F/W was crash or USB was not recognized, Set TEST pin to 3.3V before USB connect can force MCU into boot loader mode and able to update F/W via configuration tool, Default weak pull-down for input 1: Boot loader mode 0 or floating: Normal operation
24	PD_R5V	DI	Power Down pin for jack detection

Note1: GPIOs, I2C, SPI, SPDIF, MIC_JD, MIC_IN, RING2, MBIASL, MBIASR_SLEEVE, VAG, LOU TL, LOCOM, LOU TR, VOLADJ, PDSW pins can be left floating if not in use.

Note2: Suggest connect TEST pin to GND by default.

ONWAY

6 Electrical Characteristics

6.1 Absolute Maximum Ratings

Parameter	Symbol	Min.	Typ	Max.	Unit
Storage temperature	T_s	-40	-	125	°C
Digital supply voltage	XD5V_XA5V	-	-	5.5	V
ESD (Body mode)	HBM	-	±4000	-	V
ESD (Machine mode)	MM	-	±200	-	V

6.2 Recommended Operation Conditions

Parameter	Symbol	Min.	Typ	Max.	Unit
Operating ambient temperature	T_A	-15	25	70	°C
Supply voltage	XD5V_XA5V	3.3	4.3	4.7	V
MCU Clock			12.000		MHz

6.3 Power Consumption

Test Conditions: DVDD50_A5V=USB 5V, DGND =0V, $T_A=+25^{\circ}\text{C}$, MCU Clock = 12MHz @ Active, Sample Rate=48kHz, 16Bits, EQ/SPDIF-Out/A-A disable, 32ohm loading

Items	Test Conditions	Test Values			Unit
		Min.	Typ.	Max.	
Current consumption @ Power down	Jack unplugged power-down mode		0		mA
Current consumption @ Standby (Idle)	MCU clock=3MHz		12.7		mA
Current consumption @ Active	Play+Record		19.1		mA
Current consumption @ Suspend	USB Suspend		1.1		mA

6.4 DC Characteristics

Test Conditions: DVDD50_A5V=5V, DVDD33=3.3V, DGND =0V, $T_A=+25^{\circ}\text{C}$,

Parameter	Symbol	Min.	Typ	Max.	Unit
Input voltage range	DI	0	-	3.6	V
Output voltage range	DO	0	-	3.6	V
Input High-level voltage (GPIO,I2C,SPI,SPDIF)	Vih	2			V
Input Low-level voltage (GPIO,I2C,SPI,SPDIF)	Vil			0.8	V
Output High-level voltage (GPIO,I2C,SPI,SPDIF)	Voh	2.4	3.3	3.6	V
Output Low-level voltage (GPIO,I2C,SPI,SPDIF)	Vol	0		0.4	V
Output source current (GPIO, I2C,SPI,SPDIF)	IOH		8		mA
Output sink current (GPIO, I2C,SPI,SPDIF)	IOL		8		mA

6.5 Analog I/O Characteristics

Parameter	Symbol	Pin Name	Limit Values	Unit	Test Conditions
-----------	--------	----------	--------------	------	-----------------

			Min.	Typ.	Max		
Microphone Input Impedance	MII	MIC IN	20		45	k Ω	
Microphone A-A Input Impedance	MAII	MIC IN		20		k Ω	Mic Gain=0dB
Headphone Output Impedance	HPOI	HPOUT_L HPOUT_R		TBD		Ω	Master Volume =0dB
Microphone Bias Open Circuit Voltage	VMICBIAS	MIC_BIAS	2.63	2.92	3.21	V	
Microphone Bias Output Current	IMICBIAS	MIC_BIAS			1.25	mA	RMIN=2.2k Ω
Microphone Bias Output Impedance	ROUTMICB	MIC_BIAS	600	650	700	Ω	
Power Supply Rejection Ratio (PSRR) for Microphone Bias	PSRRMICB	MIC_BIAS		100		dB	Internal regulators active, at maximum load current (0.5 mA), 1 kHz sine wave at 100 mVrms

6.6 Audio Performance

- DAC Audio Quality

T_A=25°C, DVDD50_A5V=5V, 1KHz Sinewave, 48KHz/16bit, Equalizer disable
 Test Platform: DELL Desktop 32BWS02, 4G RAM, Windows 8.1 CHT

Items	Test Conditions	Test Values			Unit
		Min.	Typ.	Max.	
Full Scale Output Voltage	10K Ω loading fs=48kHz/16bit		1.0		Vrms
	32 Ω loading fs=48kHz		0.86		Vrms
THD+N	10K Ω loading fs=48kHz/16bit, -3dBFS		-86dB (@1KHz)		dB
	32 Ω loading fs=48kHz/16bit, -3dBFS		-80dB (@1KHz)		dB
Dynamic Range	32 Ω loading fs=48kHz/16bit, -60dBFS, A-Weighted		91		dB
SNR (Noise level during playback)	10K Ω loading fs=48kHz/16bit, -96dBFS, A-Weighted		95		dB
	32 Ω loading fs=48kHz/16bit, -96dBFS, A-Weighted		96		dB
Inter-Channel Phase Delay	100Hz ~ 20kHz	+0.01		+0.97	Deg
Sampling Frequency Accuracy	10K Ω loading fs=48kHz/16bit	-0.0046		+0.0078	%
Channel Separation(Crosstalk)	10K Ω loading fs=48kHz/16bit		92		dB
	32 Ω loading		68		dB

	fs=48kHz/16bit				
Frequency Response	10KΩ loading fs=48kHz/16bit	-0.075 (20Hz)		-0.967 (20KHz)	dB
Passband Ripple	10KΩ loading fs=48kHz/16bit			0.244	dB

- ADC Audio Quality

T_A=25°C, DVDD50_AV5=5V, Mic input 1KHz sinewave, Equalizer disable, Mic Gain=0dB if not specified
 Test Platform DELL Desktop 32BWS02, 4G RAM, Windows 8.1 CHT

Items	Test Conditions	Test Values			Unit
		Min.	Typ.	Max.	
Full Scale Input Voltage	Microphone fs=48kHz		800m		Vrms
THD+N	Microphone fs=48kHz/16bit, -3dBFS		-84		dB
Dynamic Range	Microphone fs=48kHz/16bit, -60dBFS, A-Weighted		90		dB
SNR (Noise level during record)	Microphone fs=48kHz/16bit, -96dBFS, A-Weighted		90 (@0dB) 86 (@+20dB)		dB
Sampling Frequency Accuracy	Microphone fs=48kHz/16bit	-0.0032		+0.0071	%
Channel Separation(Crosstalk)	Microphone fs=48kHz/16bit		80		dB
Frequency Response	Microphone fs=48kHz/16bit	0.035 (20Hz)		-0.527 (20KHz)	dB
Passband Ripple	Microphone fs=48kHz/16bit		0.244	0.3	dB

- A-A Path (Sidetone) Audio Quality

T_A=25°C, DVDD50_A5V=5V, A-A Volume=0dB, 1KHz Sinewave, Mic-In to HP-Out
 Test Platform: DELL Desktop 32BWS02, 4G RAM, Windows 8.1 CHT

Items	Test Conditions	Test Values			Unit
		Min.	Typ.	Max.	
Full Scale Output Voltage	10KΩ loading		800m		Vrms
THD+N	10KΩ loading, -3dBFS		-91		dB
Dynamic Range	10KΩ loading, -60dBFS, A-Weighted		93		dB
SNR (Noise level during active)	10KΩ loading, -96dBFS, A-Weighted		93		dB
Channel Separation (Cross-talk)	10KΩ loading,		90		dB
Frequency Response	10KΩ loading	+0.001 (20Hz)		-0.098 (20KHz)	dB
Passband Ripple	10KΩ loading			0.002	dB

7 Package Dimensions (QFN-48 pin) (5x5 mm)

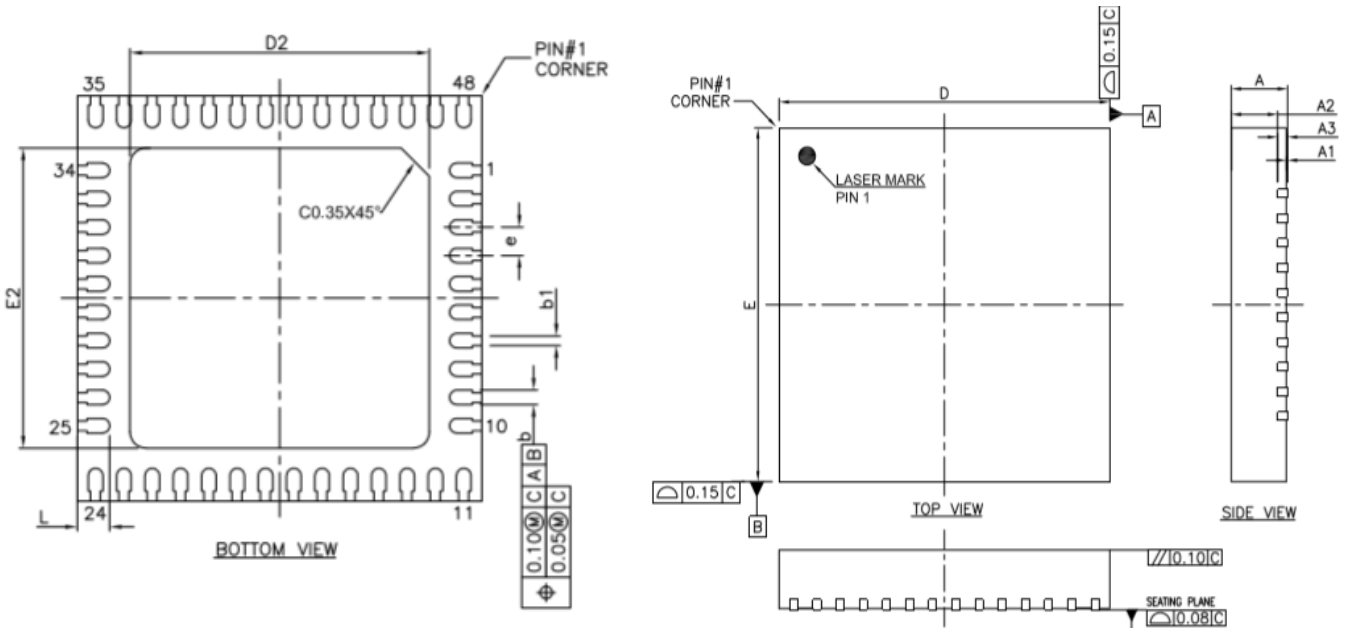

	SYMBOL	MIN.	NOM.	MAX.
Total thickness	A	0.80	0.85	0.90
Standoff	A1	0.00	0.02	0.05
Mold thickness	A2	0.65	0.70	0.75
Lead thickness	A3	0.15		0.203
Body size	D	4.95	5.00	5.05
	E	4.95	5.00	5.05
Lead width	b	0.13	0.18	0.23
	b1	0.07	0.12	0.17
Exposed pad width	D2	3.65	3.70	3.75
Exposed pad length	E2	3.65	3.70	3.75
Lead pitch	e	0.35 BSC		
Lead length	L	0.35	0.40	0.45
Lead count	N	48L		

8 Top Marking

Description:

1. Device Name: CM6542
2. Package Type: QFN 48L 5X5 mm
3. Line 1: C-Media Logo
4. Line 2: Device Name/Part Number
5. Line 3: Internal Control Code
6. Line 4: Internal Control Code (GS: Green Product)
7. Line 5: Date Code (YYWW)



Line 1

Line 2

Line 3

Line 4

Line 5

— End of Datasheet —

ONWAY

C-MEDIA ELECTRONICS INC.

6F., 100, Sec. 4, Civil Boulevard, Taipei, Taiwan 106 R.O.C.

TEL : +886-2-8773-1100

FAX : +886-2-8773-2211

E-MAIL : sales@cmedia.com.tw

Disclaimer:

Information provided by C-Media Electronics Inc. is sworn to be accurate and reliable. However, no responsibility is assumed by C-Media Electronics Inc. for its use, nor for any infringements of patents or other rights of third parties that may result from its use. Specifications are subject to change without notice. No license is granted by implication or otherwise under any patent or patent rights of C-Media. Trademarks, registered or not are the property of their respective owners.