

## DESCRIPTION

The CM2206 is a highly integrated single-chip Bluetooth audio solution targeting Bluetooth gaming headsets and wireless microphone markets with high performance and low power consumption.

CM2206 adopts RISC-V processor and integrates BT v6.0 to BT classic and 2.4G audio connection, which is fully backward compatible to the previous Bluetooth versions.

CM2206 owns a power management unit (PMU) to establish a stable power source and linear battery charger that allows CM2206 to recharge the battery over USB. With a rich set of interfaces such as USB, SPI, UART, I2C, PWM, capacitive touch key, CM2206 is able to accomplish various audio applications.

Besides, with implementing Cmedia Xear™ Sound Technology- Surround HP and AI noise cancellation, to provide users the best auditory experience at near end, and transmit good voice quality to far end by filtering out the annoying sounds around, like keyboard typing, mouse clicking, fan sound, fan blades running, etc.

## FEATURES

- 32bit RISC-V processor Core, typical speed: 140MHz
- Internal 16M bit flash
- Internal 320KB RAM for data and program
- Compliant with Bluetooth V6.0 (BR/EDR/BLE) specification
- TX Maximum output power +10.5dBm
- RX Sensitivity with -94.5dBm @2M EDR
- High performance stereo DAC with 104dB SNR, support differential mode and VCMBUF mode
- High performance mono ADC with 102dB SNR
- Support USB 2.0 Full speed
- Support 10-bit SARADC
- Build in IRTC
- Build in PMU (charger/buck/LDO)
- Support GPIO x13 with flexibly programmable pull-up and pull-down resistors
- Support GPIO wakeup or interrupt
- QFN-32 package (4 x 4 mm)

## BLOCK DIAGRAM

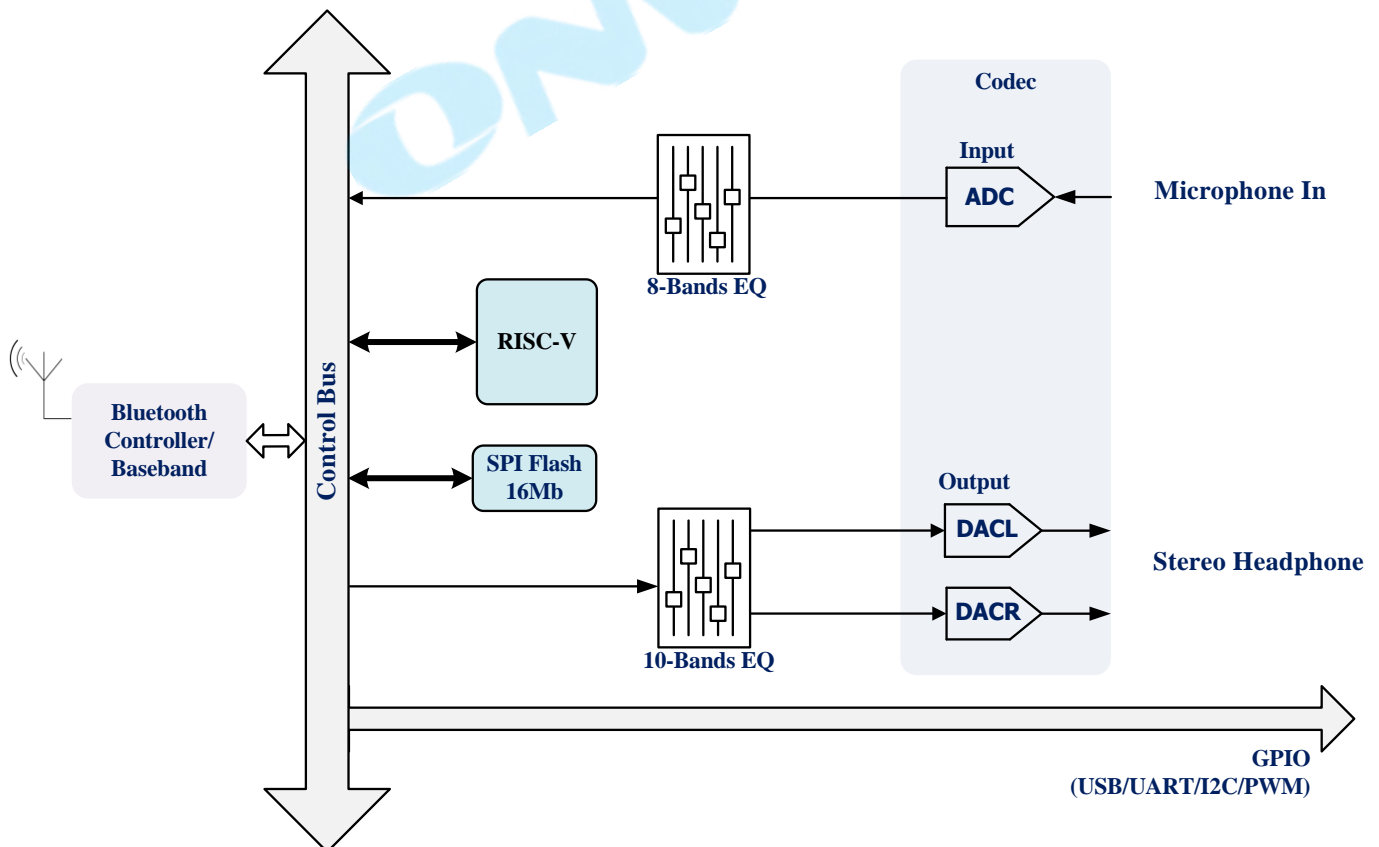

---

**Release Notes**

Revision	Date	Description
0.1	2025/05/13	First release
0.2	2025/05/28	Modify Pin description.
0.3	2025/10/09	Modify Block Diagram

ONWAY

## TABLE OF CONTENTS

1 Description and overview .....	4
2 Pin assignment.....	5
2.1 Pin-out diagram .....	5
2.2 Pin description.....	6
3 Electrical Characteristics .....	9
3.1 PMU voltage input Parameters .....	9
3.2 LDO Parameters .....	9
3.3 1.25V LDO Parameters.....	9
3.4 1.1V LDO Parameters .....	9
3.5 1.25V BUCK Parameters .....	9
3.6 1.1V BUCK Parameters .....	10
3.7 Battery Charging Parameters .....	10
3.8 IO Parameters.....	10
3.9 Internal Resistor Characteristics .....	11
3.10 BT Parameters .....	11
4 Audio performance.....	12
4.1 DAC audio quality .....	12
4.2 ADC audio quality .....	12
5 Ordering Information .....	14
6 Package dimensions(QFN-32 pin) .....	15
7 Marking Information .....	16

## 1 Description and overview

The CM2206 is a highly integrated single-chip Bluetooth audio solution targeting Bluetooth gaming headsets and wireless microphone markets with high performance and low power consumption.

CM2206 adopts RISC-V processor and integrates BT v6.0 to BT classic and 2.4G audio connection, which is fully backward compatible to the previous Bluetooth versions.

CM2206 owns a power management unit (PMU) to establish a stable power source and linear battery charger that allows CM2206 to recharge the battery over USB. With a rich set of interfaces such as USB, SPI, UART, I2C, PWM, capacitive touch key, CM2206 is able to accomplish various audio applications.

Besides, with implementing Cmedia Xear™ Sound Technology- Surround HP and AI noise cancellation, to provide users the best auditory experience at near end, and transmit good voice quality to far end by filtering out the annoying sounds around, like keyboard typing, mouse clicking, fan sound, fan blades running, etc.

ONWAY

## 2 Pin assignment

### 2.1 Pin-out diagram

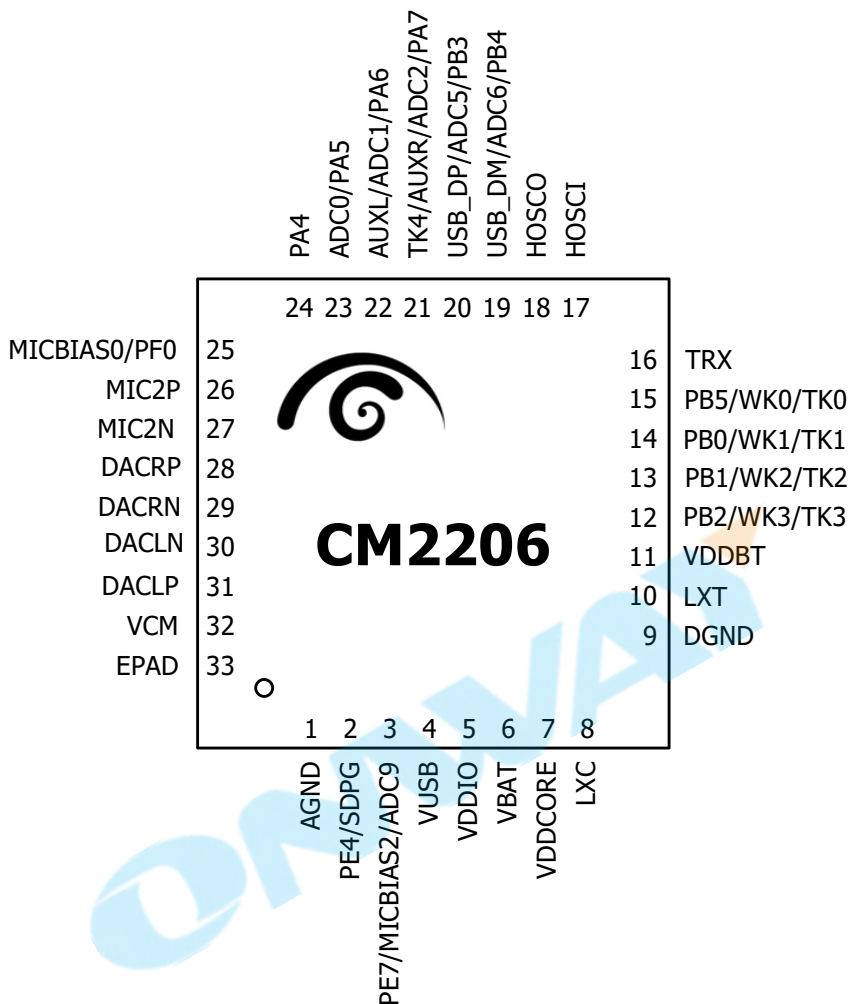

## 2.2 Pin description

Pin No.	Name	Type	Drive(mA)	Function
1	AGND	GND	/	DAC Ground
2	PE4 / SDPG	I/O	8/32	SD Power Gate IISMCLK-G2 INT1-G2 PWM5-G2 PE4
3	PE7 / MICBIAS2 / ADC9	I/O	8/32	MICBIAS2-300R ADC9 AUXR0 SDDAT0-G3 SPI1DO/SPI1DATA-G4 IISDO/DAT-G2 IIC_DAT-G5 TX0-G4 TX2-G1 HSTRX-G4 INT3-G1 PWM2-G3 TMR4CAP_G1/IR_G8 PE7
4	VUSB	PWR	/	VUSB power input
5	VDDIO	PWR	/	VDDIO power output
6	VBAT	PWR	/	VBAT power input
7	VDDCORE	PWR	/	VDDCORE power
8	LXC	PWR	/	Buck inductor interface for VDDCORE
9	DGND	GND	/	Digital Ground
10	LXT	PWR	/	Buck inductor interface for BT
11	VDDBT	PWR	/	BT power
12	PB2 / WK3 / TK3	I/O	8/32	WK3 Touch3 ADC4 SDDAT0-G2 SPI1DO/SPI1DATA-G3 IISDO/DAT-G3 IIC_DAT-G3 TX0-G2 TX2-G2 HSTRX-G2 INT2-G0 PWM0-G2 PB2
13	PB1 / WK2 / TK2	I/O	8/32	WK2 Touch2 ADC3 SDCLK-G2 SPI1CLK-G3 IISLRCLK-G3 IIC_CLK-G3/G4 RX0-G2

				RX2-G2 HSTRX-G7 INT1-G0 FMOSC-G4 PWM5-G1 TMR3CAP_G4/IR_G4 PB1
14	PB0 / WK1 / TK1	I/O	8/32	WK1 Touch1 ADC11 SDCMD-G2 SPI1DI-G3/SPI2W_DI01-G3 IISCLK-G3 IIC_DAT-G4 INT6-G0 FMOSC-G3 PWM4-G1 TMR3CAP_G3/IR_G3 PB0
15	PB5 / WK0 / TK0	I/O	8/32	10S Reset WK0 Touch0 ADC12 SPI1DI-G1 SPI2W_DIO1-G1 IISDI-G3 INT5-G0 PWM3-G2 PB5
16	TRX	A	/	Bluetooth antenna IO
17	HOSCI	A	/	24M OSC input
18	HOSCO	A	/	24M OSC output
19	USBDM / PB4 / ADC6	I/O	8/32	USBDM ADC6 SDDAT0-G4/G6 SPI1DO/SPI1DATA-G1 IISMCLK-G3 IIC_DAT-G7 RX0-G3 HSTRX-G8 INT4-G0 FMOSC-G7 PWM2-G2 PB4
20	USBDP / PB3 / ADC5	I/O	8/32	USBDP ADC5 SDDAT0-G5/SDCMD-G6 SPI1CLK-G1 IISDI-G1 IIC_CLK-G7 TX0-G3 HSTRX-G3 INT3-G0 PWM1-G2 PB3
21	PA7/ADC2/AUXR/TK4	I/O	8/32	SD Update interface ADC2 AUXR1 SDDAT0-G1 SPI1DO/SPI1DATA-G2 IISDO/DAT-G1

				IIC_DAT-G1 TX0-G1 TX1-G1 HSTRX-G1 INT0-G0 PWM3-G1 PA7
22	PA6/ADC1/AUXL	I/O	8/32	ADC1 AUXL1 SDCLK-G1/G4/G5/G6 SPI1CLK-G2 IISLRCLK-G1 IIC_CLK-G1/G2 RX0-G1 RX1-G1 HSTRX-G6 INT0-G1 FMOSC-G2 PWM2-G1 TMR3CAP_G2/IR_G2 PA6
23	PA5/ADC0	I/O	8/32	ADC0 SDCMD-G1/G4/G5 SPI1DI-G2 IISCLK-G1 IIC_DAT-G2 RTS INT0-G2 FMOSC-G1 PWM1-G1 TMR3CAP_G1/IR_G1 PA5
24	PA4	I/O	8/32	IISMCLK-G1 CTS INT0-G3 PWM0-G1 PA4
25	PF0/MICBIAS0	I/O	8/32	MICBIAS0 ADC10 IIC_CLK-G8 TX1-G2 HSTRX-G5 INT3-G2 PWM3-G3 TMR5CAP_G1/IR_G9 PF0
26	MIC2P	A	/	Microphone2 positive input
27	MIC2N	A	/	Microphone2 negative input
28	DACRP	A	/	DAC Right Channel differential positive output
29	DACRN	A	/	DAC Right Channel differential negative output
30	DACLN	A	/	DAC Left Channel differential negative output
31	DACLP	A	/	DAC Left Channel differential positive output
32	VCM	PWR	/	DAC VCM
33	EPAD	GND	/	E-pad

### 3 Electrical Characteristics

#### 3.1 PMU voltage input Parameters

Sym	Characteristics	Min	Typ	Max	Unit	Conditions
VUSB	Charger Voltage input	4.6	5.0	5.5	V	
VBAT	Voltage input	3.0	3.7	4.5	V	

#### 3.2 LDO Parameters

Sym	Characteristics	Min	Typ	Max	Unit	Conditions
VDDIO	3.3V LDO voltage output	2.4	3.3	3.6	V	Light Loading condition Step 0.1v
$\Delta$ VDDIO	Output Mismatch 1-sigma	-	17	-	mV	VDDIO=3.3v
ILOAD	Maximum output current	-	-	150	mA	@VBAT=3.6v
ISC	Short Circuit Current Limit	-	-	750	mA	@VBAT=3.8v

#### 3.3 1.25V LDO Parameters

Sym	Characteristics	Min	Typ	Max	Unit	Conditions
VDDBT/BT_AVDD	1.25V LDO voltage output	0.85	1.25	1.6	V	Light Loading condition Step 0.05v
$\Delta$ VDDBT	Output Mismatch 1-sigma	-	9	-	mV	VDDBT=1.25v
ILOAD	Maximum output current	-	-	100	mA	@VBAT=3.0v
ISC	Short Circuit Current Limit	-	-	300	mA	@VBAT=3.8v

#### 3.4 1.1V LDO Parameters

Sym	Characteristics	Min	Typ	Max	Unit	Conditions
VDDCORE	1.1V LDO voltage output	0.7	1.1	1.475	V	Light Loading condition Step 0.025v
$\Delta$ VDDCORE	Output Mismatch 1-sigma	-	6	-	mV	VDDCORE=1.1v
ILOAD	Maximum output current	-	-	75	mA	@VBAT=3.6v
ISC	Short Circuit Current Limit	-	-	300	mA	@VBAT=3.8v

#### 3.5 1.25V BUCK Parameters

Sym	Characteristics	Min	Typ	Max	Unit	Conditions
VDDBT	1.25V BUCK voltage output	0.85	1.25	1.6	V	Light Loading condition Step=0.05v
$\Delta$ VDDBT	Output Mismatch 1-sigma	-	6	-	mV	VDDBT=1.25v
ILOAD	Maximum output current	-	-	360	mA	@VBAT=3.8v
ISC	Short Circuit Current Limit	-	-	360	mA	@VBAT=3.8v

### 3.6 1.1V BUCK Parameters

Sym	Characteristics	Min	Typ	Max	Unit	Conditions
VDDCORE	1.1V BUCK voltage output	0.7	1.1	1.475	V	Light Loading condition Step=0.025v
$\Delta$ VVDDCORE	Output Mismatch 1-sigma	-	6	-	mV	VDDCORE=1.1v
ILOAD	Maximum output current	-	-	360	mA	@VBAT=3.8v
ISC	Short Circuit Current Limit	-	-	360	mA	@VBAT=3.8v

### 3.7 Battery Charging Parameters

Sym	Characteristics	Min	Typ	Max	Unit	Conditions
VUSB	Charger input voltage	4.6	5.0	5.5	V	-
VBAT <sub>float</sub>	Charge Voltage	4.15	4.20	4.25	V	VUSB>4.6V
		-	4.35	-	V	VUSB>4.75V
		-	4.40	-	V	VUSB>4.8V
		-	4.45	-	V	VUSB>4.85V
ICH	Charge current	5	-	320	mA	VBAT<=VBAT <sub>float</sub> -150mV VUSB>=VBAT <sub>float</sub> +550mV Step=5mA
Vcv2	Voltage difference of CV2	-	200	-	mV	VUSB=5V
		-	260	-	mV	
		-	320	-	mV	
		-	380	-	mV	
IEnd	End of charge current	2.5	-	37.5	mA	Step=2.5mA
VTrickle	Trickle charge Voltage	2.9	3.0	3.1	V	VUSB>4.6V

### 3.8 IO Parameters

Symbol	Description	Related GPIO	Min	Typical	Max	Units	Conditions
VIL	Low-level input voltage		-0.3		1.27	V	VDDIO=3.3V
VIH	High-level input voltage		2.03		3.6	V	VDDIO=3.3V
Driver Ability 1	Output Driver Ability 1			32		mA	VDDIO=3.3V
Driver Ability 0	Output Driver Ability 0			8		mA	VDDIO=3.3V
RPUP0	Internal pull-up resistor 0		8	10	12	K $\Omega$	
RPUP1	Internal pull-up resistor 1		0.24	0.3	0.36	K $\Omega$	
RPUP2	Internal pull-up resistor 2		160	200	240	K $\Omega$	
RPDN0	Internal pull-down resistor 0		8	10	12	K $\Omega$	
RPDN1	Internal pull-down resistor 1		0.24	0.3	0.36	K $\Omega$	
RPDN2	Internal pull-down resistor 2		160	200	240	K $\Omega$	

### 3.9 Internal Resistor Characteristics

Port	General Output	High Drive	Internal Pull-Up Resistor ( $\Omega$ )	Internal Pull-Down Resistor ( $\Omega$ )	Comment
PA4-PA7 PB0-PB5 PE0, PE5-PE7 PF0-PF1 PG0-PG5	8mA	32mA	300/10K/200K	300/10K/200K	Internal pull-up/pull-down resistance accuracy +/-20%
PE4	8mA	32mA	10K	10K	

### 3.10 BT Parameters

Characteristics	Min	Typical	Max	Unit	Conditions
Transmit Power	-	9	10.5	dBm	Maximum TX power 2-DH5 packet
RMS DEVM	-	5.5	-	%	
Peak DEVM	-	15	20	%	
EDR Relative Transmit Power	-	-0.2	-	dB	
Sensitivity @ Basic Rate	-	-94.5	-	dBm	BER=0.1%, using DH5 packet
Sensitivity @ EDR	-	-94.5	-	dBm	BER=0.01%, using 2-DH5 packet

## 4 Audio performance

### 4.1 DAC audio quality

Mode	Sym	Characteristics	Min	Typ	Max	Unit	Conditions
Differential Mode	SNR		-	104.1	-	dB	VCM cap=1uF VDDDAC cap=NC with 32Ω loading Fin=1KHz
	THD+N		-	-93	-	dB	VCM cap=1uF VDDDAC cap=NC with 32Ω loading Fin=1KHz
	Max Output Range		-	-2.4		dBV	32ohm Loading
VCMBUF Mode	SNR			96.2		dB	VCM cap=1uF VDDDAC cap=NC with 32Ω loading Fin=1KHz
	THD+N			-77.6		dB	VCM cap=1uF VDDDAC cap=NC with 32Ω loading Fin=1KHz
	Max Output Range			-8.6		dBV	32ohm Loading

### 4.2 ADC audio quality

Mode	Sym	Characteristics	Min	Typ	Max	Unit	Conditions
ADC Mode	SNR		-	102	-	dB	VCM cap=NC VDDMIC cap=1uF Input -2dBV @ Fin=1KHz
	THD+N		-	-97	-	dB	
	Input Range	Maximum input voltage	-	-2	-	dBVrms	
PGA + ADC DIFF Mode	PGA Gain		-6		42	dB	-6 / 0~42dB@step=3dB
	SNR			94		dB	VCM cap=NC VDDMIC cap=1uF differential input Input 0dBV @ Fin=1KHz PGA Gain=0dB
	THD+N			-86		dB	
	Input Range	Maximum input voltage	-	3	-	dBVrms	
PGA + ADC	PGA Gain		-6		42	dB	-6 / 0~42dB@step=3dB

Mode	Sym	Characteristics	Min	Typ	Max	Unit	Conditions
SINGLE Mode	SNR			92		dB	VCM cap=NC VDDMIC cap=1uF single input Input 0dBV @ Fin=1KHz PGA Gain=0dB
	THD+N			-63		dB	
	Input Range	Maximum input voltage	-	1	-	dBVrms	

ONWAY

## 5 Ordering Information

Product Name	Package Marking	Package Type	Transport Media	Storage Temperature
CM2206	CM2206	QFN-32 (4 x 4 mm) Green Package	Tray	-45 to 120 °C

ONWAY

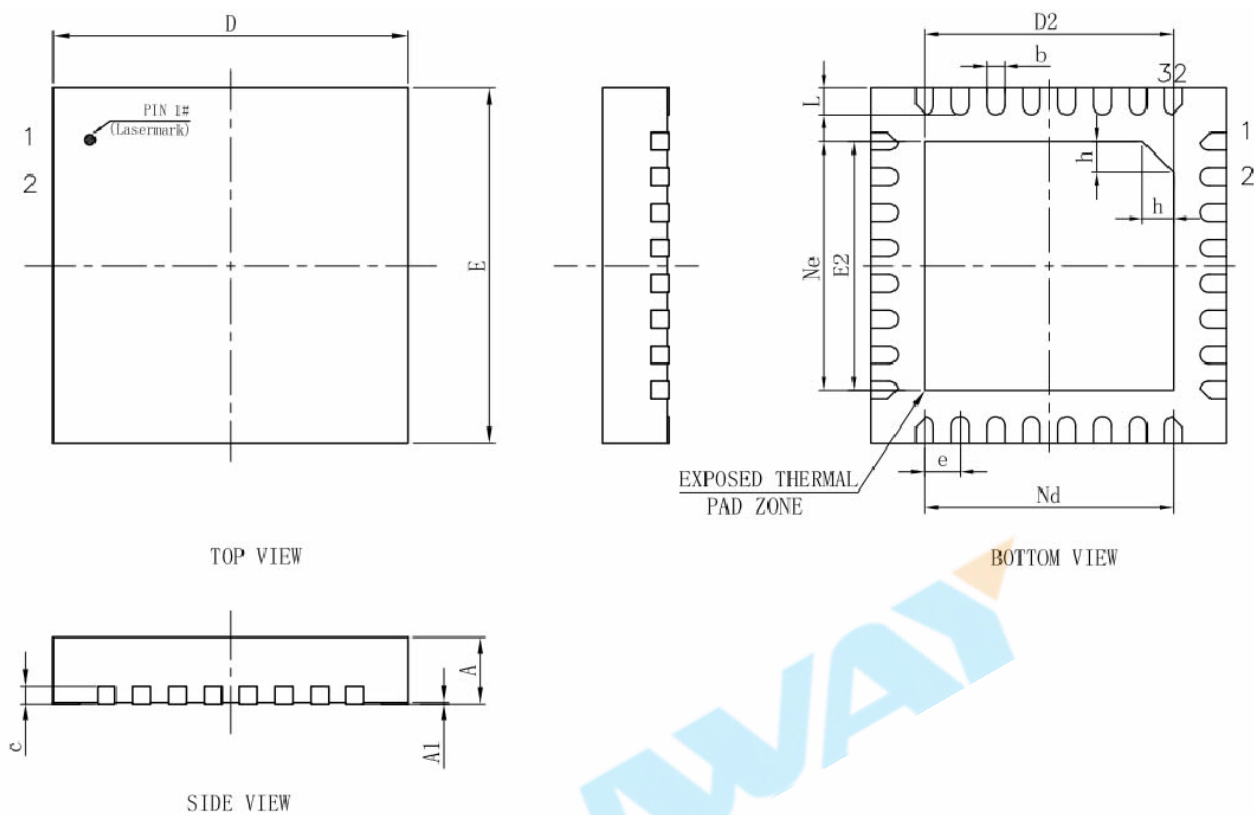
**6 Package dimensions(QFN-32 pin)**

SYMBOL	MILLIMETER		
	MIN	NOM	MAX
A	0.70	0.75	0.80
A1	0	0.02	0.05
b	0.15	0.20	0.25
c	0.18	0.20	0.25
D	3.90	4.00	4.10
D2	2.70	2.80	2.90
e	0.40BSC		
Ne	2.80BSC		
Nd	2.80BSC		
E	3.90	4.00	4.10
E2	2.70	2.80	2.90
L	0.25	0.30	0.35
h	0.30	0.35	0.40
L/F载体尺寸	122X122		

## 7 Top Marking

### Description:

- Device Name: CM2206
- Package Type: QFN 32 4X4 mm
- Line 1: C-Media Logo
- Line 2: Device Name/Part Number
- Line 3: Internal Control Code
- Line 4: Internal Control Code (GS: Green Product)
- Line 5: Date Code (YYWW)



—End of Datasheet—

ONWAY

C-MEDIA ELECTRONICS INC.  
6F., 100, Sec. 4, Civil Boulevard, Taipei, Taiwan 106 R.O.C.  
TEL : +886-2-8773-1100  
FAX : +886-2-8773-2211  
E-MAIL : sales@cmedia.com.tw

Disclaimer:

Information provided by C-Media Electronics Inc. is sworn to be accurate and reliable. However, no responsibility is assumed by C-Media Electronics Inc. for its use, nor for any infringements of patents or other rights of third parties that may result from its use. Specifications are subject to change without notice. No license is granted by implication or otherwise under any patent or patent rights of C-Media. Trademarks, registered or not are the property of their respective owners.